



正信光电科技股份有限公司  
ZNSHINE PV-TECH CO.,LTD

---

# Mounting Manual

## INSTALLATION INSTRUCTION FOR 320W SERIES SOLAR MODULE

320W series solar modules are made of 72pcs of 158mm×158mm crystalline solar cells in series with high efficiency, high transmission and low iron toughened glasses , anti-aging EVA and high flame-resistant back sheet to laminate, and anodized aluminum alloy frame. Products have high efficiency, lifespan easy installation, high wind resistance etc.

Products are made according to international standard ( IEC 61215: 2016 IEC 61730: 2016 ) and have passed authority test center's examination. Our products can be used in home roof solar systems, PV stations, communication stations, petrol, ocean, meteorological, traffic and solar building etc.

320W series solar modules mainly include 315W、320W、325W、330W、335W、340W.

### 1、Electrical Specification Poly-Si series

**PHOTOVOLTAIC MODULE**

Model	ZXP6-72-315/P	ZXP6-72-320/P	ZXP6-72-325/P	ZXP6-72-330/P	ZXP6-72-335/P	ZXP6-72-340/P
Number of cells(pcs)	72	72	72	72	72	72
Pmpp(W)	315±3%	320 ±3%	325±3%	330 ±3%	335±3%	340±3%
Voc(V)	46.2±3%	46.4±3%	46.6±3%	46.8±3%	47.0±3%	47.2±3%
Isc(A)	8.97±3%	9.05±3%	9.12±3%	9.16±3%	9.22±3%	9.28±3%
Vmpp(V)	36.9	37.1	37.3	37.5	37.7	37.9
Imp(A)	8.54	8.63	8.72	8.80	8.89	8.98
Max series fuse rating(A)	15					
Nominal Mass	22.5kg					
Package Size	1960mm×992mm×40mm					
Cell Size	158mm×158mm					
<b>MAX</b> System voltage	DC1500V					
Coefficient of cells	$\alpha$ [%/ °C]: 0.06					
	$\beta$ [%/ °C]: -0.31					
	$\gamma$ [%/ °C]: -0.408					

- The electrical characteristics are within  $\pm 3$  percent of the indicated values of  $I_{sc}$ ,  $V_{oc}$  and  $P_{mp}$  under test conditions (irradiance of  $1000W/cm^2$ , AM1.5 spectrum, and a cell temperature of  $25^{\circ}C$ )

- Under normal conditions, a photovoltaic module is likely to experience conditions that produce more current and/or voltage than reported at standard test conditions. Accordingly, the values of  $I_{SC}$  and  $V_{OC}$  marked on this module should be multiplied by a factor of 1.25 when determining component voltage ratings, conductor current ratings, fuse sizes, and size of controls connected to the PV output."

- Refer to section 690-8 of the NEC for an additional multiplying factor of 156 percent which may be applicable.

- Installation should be in accordance with AS/NZS 5033, Safety Standard for Electrical Installations.

## 2、Appearance character:

No.	Item	Remark
1	Measurement	length: 1960mm width: 992mm height: 40mm
2	Weight	22.5kg
3	Cell	72pcs (158mm×158mm) solar cells, 6 lines 12 rows connected in series and array in matrix.
4	Output cable	4mm <sup>2</sup> cable with TUV certification, with polarity mark, waterproof, length is 1200mm .
6	Structure	Front: high transparent toughened glass Front: high transmission toughened glass with 3.2 mm (1/8inch) height Back: Polyester Material : EVA
7	Frame	Anode oxidation. Aluminum alloy frame Color: Silver
8	Insulated performance	50M $\Omega$
9	Max system voltage	1500V

### 3、Structure

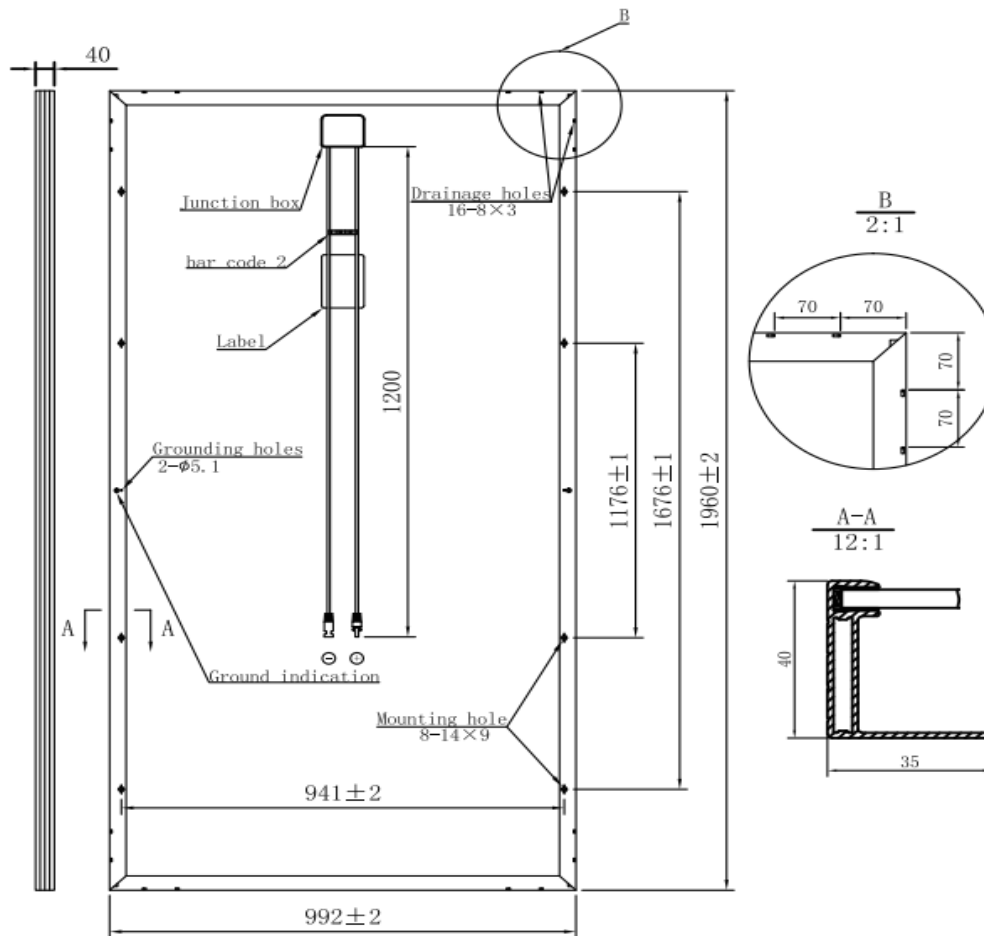

### 4、Operating environment

#### CLIMATE CONDITION

#### Install the PV module in the following conditions:

- Environment temperature:  $-20^{\circ}\text{C}$  to  $40^{\circ}\text{C}$ 。
- Operating temperature:  $-40^{\circ}\text{C}$  to  $80^{\circ}\text{C}$ 。
- Waterproof: don't dip the modules into the water or continually explode under the water device or fountain.
- Antisepsis: keep away from salt erode and sulfuration places
- Do not wear rings, jewelry, watches or other metallic items while working with photovoltaic modules.

### 5、Mounting and notes

- The modules' electrical performance in a system is the same. When connected in series, all modules must have the same amperage. When connected in parallel, the modules must all have the same voltage. Connect the quantity of modules that match the voltage specifications of the devices used in the system. The modules must not be connected together to create a voltage that is higher than the permitted system voltage.
- To minimize risk in the event of an indirect lightning strike, avoid forming loops when designing the system.
- Modules must not be fitted as overhead glazing. Ensure that the mounting system can also withstand the anticipated wind and snow loads.
- Precipitate can run off through small openings on the back side of the module. Make sure that the openings are not masked after mounting.
- The modules have passed mechanical load test (2400\*1.5) Pa, 1.5 is a security factor, To avoid exceeding the maximum load, site-specific live loads such as wind and snow should be taken into account.
- The installation of project must be facing north in the southern hemisphere, and facing south in the northern hemisphere, the electricity will be comparatively lower when the project facing west or east. The incorrect installation will lead to the loss of power

RECOMMENDED TILT ANGLES FOR A FIXED SYSTEM	
SITE LATITUDE IN DEGREES	FIXED TILT ANGLE
0° TO 15°	15°
15° TO 25°	SAME AS LATITUDE
25° TO 30°	LATITUDE+5°
30° TO 35°	LATITUDE+10°
35° TO 40°	LATITUDE+15°
40° +	LATITUDE+20°

- The modules, which are connected in series, must be in the same angle, otherwise, it will lose power because of the difference in sunlight intensity. Solar modules generate the power to the maximum when they are pointed directly at the sun. For installations where the solar modules are mounted to a permanent structure, the solar modules should be tilted for optimum winter performance. As a rule, if the system power output is adequate in the winter, it will be satisfactory during the rest of the year. The module tilt angle is measured between the solar modules and the ground.

FIGURE

FIGURE

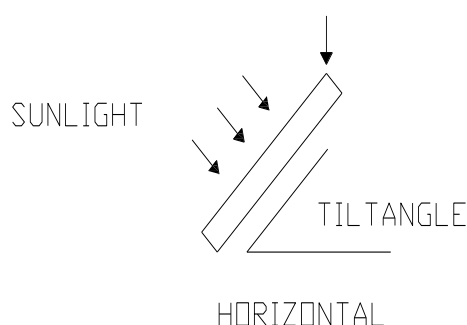

- Avoid installing under the shadow, even the module factory use the bypass diode to decrease the loss of energy, the shadow will lead to the loss of output power.

## 6、Grounding

- All module frames must be attached to an earth ground. A qualified electrician must do the ground connection .The cable which connects the earth must be copper wire with 12AWG.

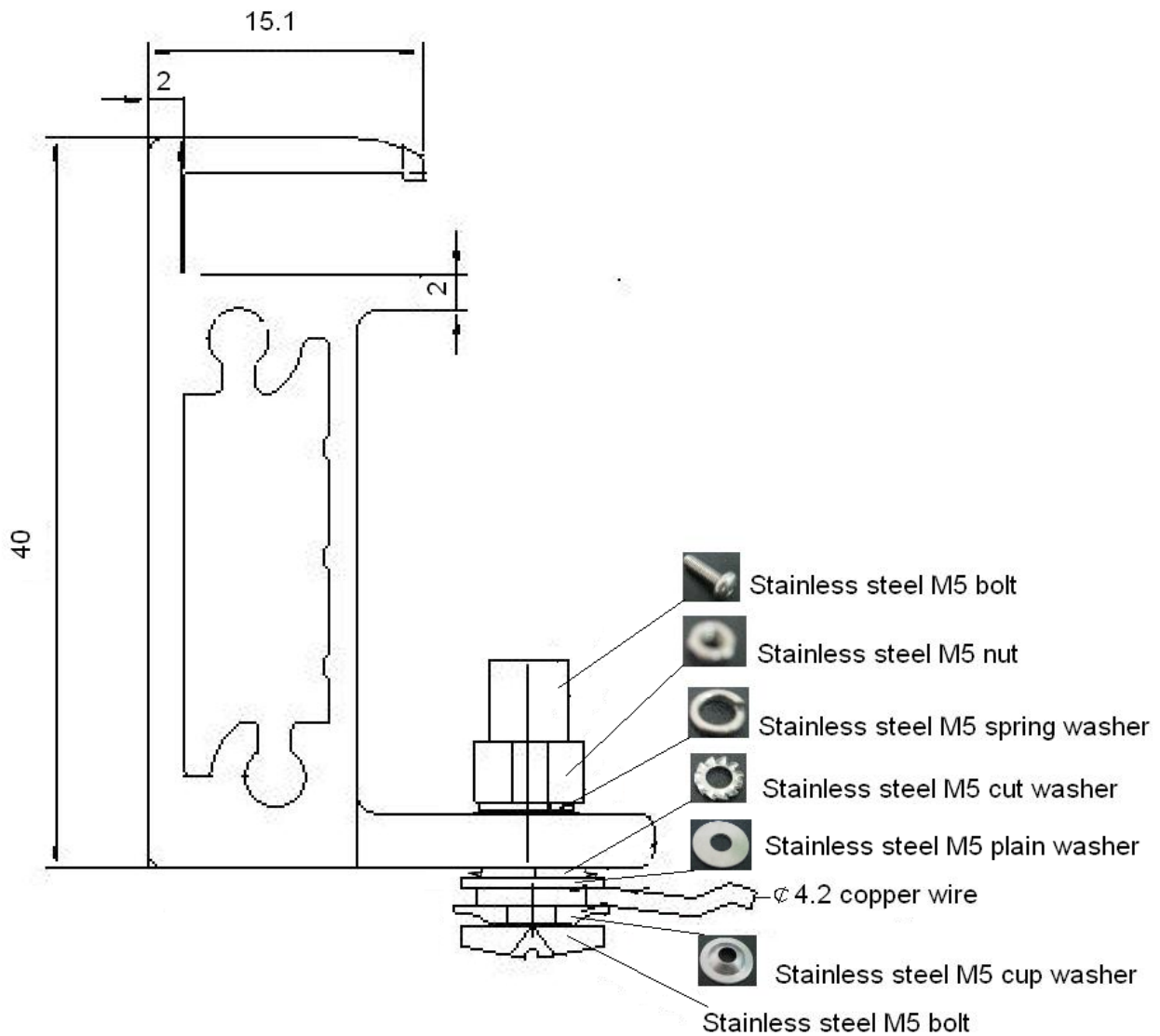

- Use the holes(5.0mm) marked '⊕'. To create the conductive connection (frame is anodized), use Stainless steel M5nut, two Stainless steel cut washer, Stainless steel M5 plain washer, Stainless steel M5 spring washer , M5 copper wire ,and Stainless steel M5 bolt.

1. Copper wires with M5 cupped washer should be placed through the bolt;
2. Put the cut washer through the bolt, and the bolt must be put through the hole fixed in the aluminum frame;

3. Use the nut and cut washer to fix all the parts. The copper wire can not be attached to the aluminum.

- Do not interrupt or influence the conductive connection when making daily maintenance .All the crunodes on the conductive connection must be fixed. The fastness does not depend on soldering.

## 7、 Suggested maximum number of modules in parallel and in series

- When designing the system, we Suggested maximum number of modules in parallel and in series for  $[V_{sys}/(1.25V_{oc})]/1$ 、 fuse rating/ $I_{sc}+1$ .

## 8、 Mounting

- Photovoltaic modules should be installed below 2000 meters above sea level, Artificially concentrated sunlight shall not be directed on the module or panel.
- We recommend using a torque wrench for installation. The tightening torque(using stainless steel M8 bolts 、 Stainless steel washer and Stainless steel M8 nut ) should be around 15-20Nm.Use the existing holes to secure the module and do not drill additional holes(doen so would void the warranty).Use appropriate corrosion-proof fastening material.
- Clearance between the module frame and mounting surface may be required to prevent the junction box from touching the surface, and to circulate cooling air around the back of the module. If the modules are to be installed on the roof or wall of a building, the standoff method or the rack method is recommended. *Stand-off method:* The modules are supported parallel to the surface of the building wall or roof. Clearance between the module frames and surface of the wall or roof is required to prevent wiring damage and to allow air to circulate behind the module. The recommended stand-off height is 115mm. If other mounting means are employed, this may affect the Listing For Fire Class Ratings.

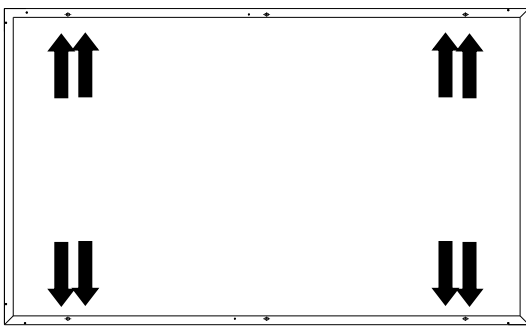

Example for mounting the PV modules to the substructure:

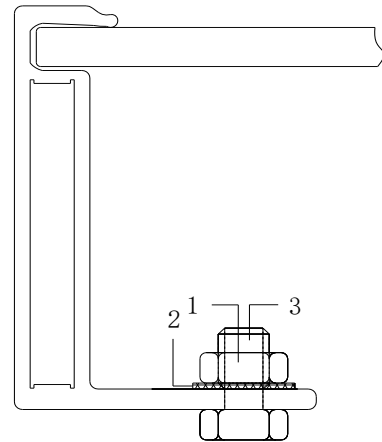

- 1、 Stainless steel M8 nut
- 2、 Stainless steel washer
- 3、 Stainless steel M8 t-head bolt

- Installation of the rooftop  
Roof installation needs to meet local safety regulations.  
When doing installation on roof and building, make sure that the modules are fastened. This will prevent them from falling down in extreme weather.  
Do comply the safety regulations and use appointed secure equipment.

Make sure there is enough ventilation at the back of solar modules to help ease the installation and prevent the hydrometeor

Make sure there is enough area between the installation planes and the back of the modules; minimum distance: 40mm

## 9、Wiring

- The modules use the PV-JX1201H type junction box. This box, on the back side of the module, is weatherproof and is designed to be used with standard wiring or conduit connections. Wiring methods should be in accordance with the NEC (National Electrical Code). Bypass diodes and cable clamps are included with each module when shipped from the factory.
- **Correct wiring scheme**  
When designing the system, avoid forming loops to minimize risk in the event of an indirect lighting strike. Check that wiring is correct before starting the generator. If the measured open circuit voltage ( Voc) and short-circuit current (Isc) differ from the specifications, then there is a wiring fault.
- **Correct connection of contact plug connectors**  
The plug connector has its own polarity. Make sure that the connection is safe and tight. The plug connector should not receive outer stress. Otherwise, it is only used to connect the circuit!
- **Use of suitable material**  
Use cable extensions and plugs that are designed for outdoor application. Ensure that they are in perfect electrical and mechanical condition. Use only cables having one conductor. Select the appropriate cable diameter to minimize voltage drop (to calculate the minimum cable diameter and the fuse, and to calculate controls, multiply the Isc and Voc by a factor of 1.56).  
If the module is connected to the control box, you must choose the control box with LJQ-1 type Connectors.

## 10、Bypass diodes

The type, voltage rating, current rating of the diodes are respectively

**Manufacturer:** Taizhou jinxiu Electrical Science&Technology Co.,Ltd. **Type:** SPA2040;  
**HY Electronic Corp.**

**Used in Type:** PV-JX1201H.

Partial shading of an individual module can cause a reverse voltage across the shaded module. Current is then forced through the shaded area by the other modules.

When a bypass diode is wired in parallel with the series string, the forced current will flow through the diode and bypass the shaded module, thereby minimize module heating and array current losses. Diodes are used as bypass diodes:

There are six bypass diodes per module, and 24 cells per bypass diode

## 11、Battery

When solar modules are used to charge batteries, the battery must be installed in a manner which will insure the performance of the system and the safety of the users. The battery should be away from the main flow of



people and animal traffic. Select a battery site that is protected from sunlight, rain, snow, debris, and is well ventilated. Most batteries generate hydrogen gas when charging, which is explosive. Do not light matches or spark near the battery bank. When a battery is installed outdoors, it should be placed in an insulated and ventilated battery case specifically designed for the purpose.

## **12、 Maintenance and cleaning**

- Do not change the PV components optionally (diode, junction box, plug connectors )
- Given a sufficient tilt (at least 15 °), it is not generally necessary to clean the modules (rainfall will have a self-cleaning effect). In case of heavy soiling (which will result in output reductions), we recommend cleaning the modules using plenty of water (from a hose) without cleaning agents and using a gentle cleaning implement (a sponge). Dirt must never be scraped or rubbed away when dry, as this will cause micro-scratch. We recommend that the system be inspected at regular intervals.

## **13、 Checklists:**

- All fastenings are tight and secure and free of corrosion.
- All cable connections are secure, tight, clean and free of corrosion.
- Cables are not damaged in any way.
- Check the earthing resistive of metals.

## 14、 Danger of death from electric shock!

Solar modules generate electricity as soon as they are exposed to light. One module on its own is below the safety extra low volt level, but multiple modules connected in series (summing the voltage) or in parallel (summing the current) represent a danger. The following points must be observed when handling the solar modules to avoid the risk of fire, sparking and fatal electric shock.

- Do not insert electrically conducting parts into the plugs or sockets!
- Do not fit solar modules and wiring with wet plugs and sockets!
- Exercise utmost caution when carrying out work on wiring and safety equipment (use insulated tools, insulated gloves, etc.)!
- Do not use damaged modules! Do not dismantle modules! Do not mark on the rear of the module using sharp objects!
- Exercise utmost caution when working on wiring and the inverter. Be sure carefully to follow manufacture's installation instructions!
- Artificially concentrated sunlight shall not be directed on the modules or panels!

## 15、 Danger of death from arcing !

Modules generate direct current when light shines on them. An arc may be produced when connections are separated. We therefore recommend covering modules with a lightproof cloth during installation. When breaking a connected string of modules (e.g. when disconnecting the DC line from the inverter under load), a lethally strong arc can occur:

- **Never disconnect the solar generator from the inverter while the inverter is connected to the mains grid—remove the fuse from the AC side on the inverter first!**
- **Ensure cable connections in perfect condition (no splitting, soiling or other contamination)!**

Remark: all sizes are measured in mm; and tolerance +/- 2 mm

**Website:** [www.znshine.com](http://www.znshine.com)

**Address:** #1 Zhixi Industry Zone, 213251 Jintan, Jiangsu, PEOPLE'S REPUBLIC OF CHINA

**Tel :** +86 519 68220253

**Fax :** +86-519-85322976