



Astivita Limited
15 Suscatand Street
Rocklea QLD 4106
Ph: 1300 302 084

Email: service@astivita.com.au

Astivita Limited ABN 46 139 461 733

Installation Instructions and Owner's Manual

SP Series Split Solar Water Heater



This manual uses the following conventions and symbols to highlight points of note throughout the manual.



Read this manual before you start to use this equipment.



SAFETY WARNING! Important Safety Instructions.



WARNING! Failure to follow the instructions in this manual can cause serious injury and or equipment failure.



Astivita Limited
15 Suscatand Street
Rocklea QLD 4106
Ph: 1300 302 084

Email: service@astivita.com.au

Astivita Limited ABN 46 139 461 733



GENERAL NOTICE

This water heater must be installed and serviced by a qualified person.

WARRANTY / SERVICE – Contact Astivita Limited, 15 Suscatand street, Rocklea, Brisbane QLD 4106. Ph: 1300 302 084 or email service@astivita.com.au

INSTALLER – PLEASE LEAVE THIS INSTALLATION AND OWNER’S MANUAL AND THE COMPLETED INSTALLATION CHECK LIST WITH THE HOMEOWNER



WARNING – INSTALLER PLEASE NOTE Plastic pipe must not be used on a solar water heater installation due to the effects of high water temperatures and pressures. **USE COPPER PIPE ONLY.** All compression fittings must use brass or copper olives.

Notice to Victorian Customers from the Victorian Plumbing Industry Commission

This water heater must be installed by a licensed person as required by the Victorian Building Act 1993. Only a licensed person will give you a Compliance Certificate, showing that the work complies with all relevant Standards. Only a licensed person will have insurance protecting their workmanship for six years. Make sure you use a licensed person to install this water heater and ask for your Compliance Certificate.

Installation and service must be performed by an authorised and qualified person. This water heater must be installed in accordance with:

- 1. Manufacturer’s Installation Instructions**
- 2. AS/NZS 3500.4 “National Plumbing & Drainage Code”**
- 3. AS/NZS 3000 “Wiring Rules”**
- 4. Relevant Occupational Health & Safety Regulations**
- 5. Municipal Building Codes (including NZ Building Code if installed in New Zealand)**
- 6. Any other relevant Local, State or Federal Statutory Regulations**



Astivita Limited
15 Suscatand Street
Rocklea QLD 4106
Ph: 1300 302 084

Email: service@astivita.com.au

Astivita Limited ABN 46 139 461 733

Please note: When making a service call, it is imperative that the 6-digit water heater serial number, located on the technical label, is quoted.

THIS UNIT IS NOT SUITABLE FOR USE AS A POOL OR SPA HEATER

Note: Whilst every care has been taken to ensure the accuracy in preparation of this document, no liability can be accepted for errors or omissions and any subsequent consequences that may arise. Specifications and materials may change without notice.



WARNING FOR INSTALLER – IMPORTANT INSTALLATION INSTRUCTIONS

- This page of brief instruction is to be read in conjunction with other plumbing and electrical installation requirements contained within this Installation Instruction and Owner's Manual**
- All installation work must be carried out by an appropriately qualified Tradesperson/s.**
- The installation must be performed by Qualified and Authorised Persons and comply with the requirements of AS/NZS 3500.4, AS/NZS 3000, and all local codes and regulatory authority requirements.
- CAUTION:** in order to avoid a hazard due to inadvertent resetting of the thermal cut-out, this appliance must not be supplied through an external switching device, such as a timer, or connected to a circuit that is regularly switched on and off by the utility.
- It is recommended the solar storage tank be installed at ground or floor level. The water heater must stand vertically upright **on a suitable & solid base structure.**
- This Water Heater Is Not Suitable For Pool Heating**
- Section 4 "Solar Collector Installation" must be read and understood prior to installation of collectors to roof top.
- Plastic pipe must not be used on a solar water heater installation due to the effects of high water temperatures and pressures. **USE COPPER PIPE ONLY.** All compression fittings must use brass or copper olives.
- Hot and cold copper pipes to and from the collectors must be completely insulated with a suitably temperature rated insulation that is UV rated and weatherproof with minimum thickness of 19mm.
- Valves and fittings supplied with this water heater are supplied with insulation covers which must be fitted as part of the solar installation. Failure to fully insulate pipework and fittings increases the risk of freeze damage and will void warranty
- The maximum height of solar flow and return pipes must be where these pipes enter and exit the solar collectors to avoid the possibility of air locks in the solar installation.



Astivita Limited
15 Suscatand Street
Rocklea QLD 4106
Ph: 1300 302 084

Email: service@astivita.com.au

Astivita Limited ABN 46 139 461 733

12. The maximum length of the copper tube from the solar pump to the collectors is reliant on mains pressure (minimum 200kPa Maximum inlet water pressure of 500kpa) and the number of bends and fittings in the run. As a guide, for DN15 copper pipe, the maximum length should not exceed 20 metres for 2 collectors and 15 metres for 3 collectors. Note that maximum pipe lengths are based on minimal bends.
13. Valves and fittings supplied with this solar water heater form part of the installation and must be fitted in accordance with this manual.
14. The pump and controller assembly is fitted with an AVG Flow Meter FM15-1.4. This flow meter is pre-set to 1.0L/Min for optimal performance and must not be adjusted at time of installation.
15. Working on roofs should always be considered a hazardous activity; by law you must observe certain minimum safety precautions. These safety precautions are outlined in the Work Cover Code of practice "Safe work on roofs" Part 1 and 2 and in the Occupation Health and Safety Act 2011.
16. Means for disconnection must be incorporated in the fixed wiring in accordance with the wiring rules.
17. A 240V 50 Hz 10 Amp power outlet, connected to continuous tariff, is required for the pump and controller and must be installed by a licensed Electrician. This may be a weatherproof outlet depending on location. **Steps should be taken to ensure power point is not turned off or plug pulled out as the solar controller is the primary frost protection for the solar system.**
18. The responsibility for all OH&S issues relating to the installation of the system resides with the installing tradesperson/s.
19. The system should only be connected to water supply of acceptable quality otherwise the warranty provided for the system may become void. Refer to Warranty conditions and section entitled "Water Supply" contained within this manual.
20. Frost Protection Valves (FRPRVA) are available from Astivita and should be fitted in areas that experience frost or freezing conditions (below 5°C). See detail herein entitled "Frost Protection Kits".
21. The PTR valves and the Cold Water Expansion valve must be fitted with a drain to legal discharge points where the water discharge will be clear of any paved areas and will not cause damage or injury. Do not block or seal these drain lines.
22. This water heater is intended to be installed as a fixed appliance and must be installed on a hard, level surface. If installation is to be in a wet area or a concrete floor, ensure the water heater is mounted on a suitable and substantial raised base (e.g. wood or concrete)
23. The use of a self-draining safe-tray may be required in accordance with the provisions of AS/NZS 3500.4, Clause 5.4.2.
24. Please refer any queries relating to the design and/or installation of ASTIsola products or components to the Technical Services Department in writing.
25. Rough-In Dimensions for ASTIsola Tanks as follows:

Astivita Limited ABN 46 139 461 733

**SOLAR POWER & THERMASOL ELECTRIC BOOST WATER HEATER PIPEWORK
 ROUGH IN DIMENSIONS**

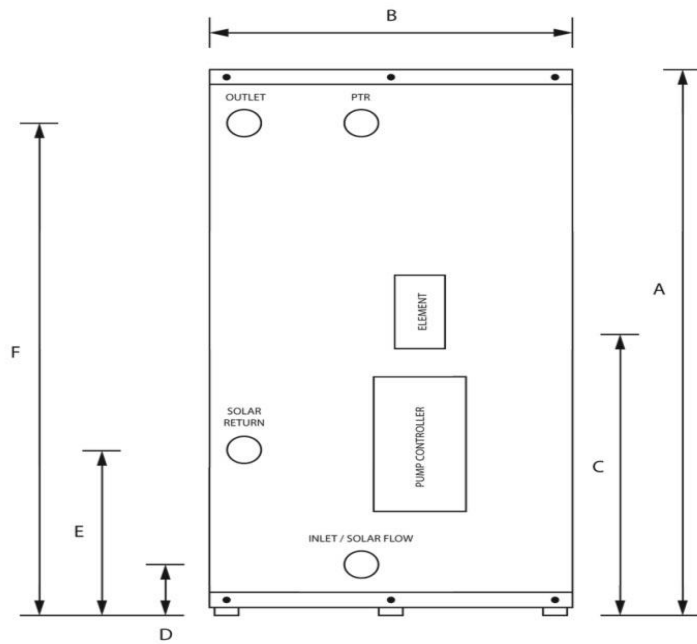

ROUGH IN PIPEWORK DIMENSIONS (mm)

MODELS	A - HEIGHT	B - DIAMETER	C - MID ELEMENT	D - INLET	E - SOLAR RETURN	F - OUTLET & PTR VALVE
SPS-270	1408	648	748	82	569	1169
SPS-340	1711	648	912	82	687	1472
SPS-450	1733	732	903	83	673	1473

NOTE: Solar flow rough-in height - 700mm for all models

VER 2.0 NOV 2012
 TECHNICAL DATA SUBJECT TO CHANGE

CONTENTS

Important information for the householder.....6

Householder instructions and maintenance.....8

 Electric Boost.....8



Astivita Limited
15 Suscatand Street
Rocklea QLD 4106
Ph: 1300 302 084
Email: service@astivita.com.au

Astivita Limited ABN 46 139 461 733

Safety valves and Frost Protection valves.....	9
Maintenance.....	9
Householder fault finding.....	11
Solar Tank Installation.....	12
Solar Controller and Pump operation.....	14
Mounting Kit.....	19
Solar Collector Installation.....	23
Mounting Kit.....	29
Frost Protection Kits.....	30
Filling & Commissioning the Installed Solar Water Heater.....	31
Product Warranty.....	34



Astivita Limited
15 Suscatand Street
Rocklea QLD 4106
Ph: 1300 302 084

Email: service@astivita.com.au

Astivita Limited ABN 46 139 461 733



1. IMPORTANT INFORMATION FOR THE HOUSEHOLDER

ASTIsola models have roof mounted solar panels connected to a ground mounted solar storage tank and/or boosting heater. The solar input is harvested with a circulation pump controlled by an electronic temperature differential controller.

1. It is important for the householder to become familiar with the contents of this manual to ensure safety and to optimise the performance and longevity of this water heater.
2. This water heater is designed for use by a single family domestic dwelling to provide hot potable water.
3. Do not operate this water heater until all operating instructions have been read and understood by the homeowner.
4. These water heaters are NOT recommended for connection to Bore Water Supplies and warranty may be void in such installations.
5. A properly drained safe tray must be used where property damage could occur from water spillage (see AS3500.4.2). Ensure this safe tray does not become blocked.
6. If you live in an area that experiences frost in winter months or freezing occurs (below 5°C), please ask your installer to install ASTIsola Frost Protection Valves (FRPRVA) to assist with preventing damage to panels. Note that this is a secondary frost protection mechanism as the solar water heater is equipped with an electronic freeze control system that will pump water from the storage tank through the collectors when the temperature of the water in the collectors reduces to 3° Celsius. This process will cease when the water temperature in the collectors rises to 5° Celsius and may repeat while the temperature is low. It is imperative that the power supply to the pump and controller is not interrupted or turned off. Damage to the panels caused by freeze conditions which occur below 5° Celsius when the power is interrupted or turned off is not covered by warranty. **Frost valves only work when under pressure from the connected water supply, so if your water pressure is supplied via a pressure pump (tank water) you must ensure the pressure pump has uninterrupted power supply if there is a black out during frost conditions.**
7. If you live in an area that experiences frost in winter months or freezing occurs (below 5°C), **DO NOT** install any form of switch to isolate the booster element as your tank is required to be heated to the minimum of 60° Celsius which forms part of the electronic frost protection system ensuring hot water is pumped to the panels. **Off peak tariffs are NOT RECOMMENDED.** It is highly recommended to connect the electric element to continuous power in frost areas to ensure water temperature in the tanks is kept.
8. Do not activate the power supply to this water heater unless the cylinder is filled with water and a satisfactory Megger reading is obtained by a qualified tradesperson.
9. Do not block or seal the Pressure & Temperature Relief (PTR) safety valve or drain pipe. Never fit a PTR or Expansion Control Valve (ECV) with a pressure rating greater than that indicated on the product-rating label.



Astivita Limited
15 Suscatand Street
Rocklea QLD 4106
Ph: 1300 302 084

Email: service@astivita.com.au

Astivita Limited ABN 46 139 461 733

10. The water heater warranty can become void if relief valves or other safety devices are tampered with or if the installation is not in accordance with these instructions.
11. Do not place any articles, chemicals or flammable materials on or near the water heater
12. Removal of access covers will expose 240V wiring. Do not remove the terminal box cover or gain access to this water heater unless the power supply has been effectively disconnected by a qualified tradesperson only.
13. Do not operate this water heater with the terminal box cover removed or loose.
14. This water heater is not intended to be operated or adjusted by young children or infirm persons. Young children must be supervised to ensure they do not interfere with the water heater.
15. **This water heater can deliver water at temperatures which can cause scolding. Check the water temperature before use, such as when entering a shower or filling a bath or basin.**
16. Take care not to touch copper pipes connected to the water heater as high temperatures in the pipework may be present.
17. The water heater pump / controller must be plugged into a 240V 50Hz 10Amp electrical outlet which may be required to be weatherproof depending on location. Take care not to touch the power plug with wet hands.
18. If the power supply cord, plug or electrical conduit to the water heater is damaged, it must be replaced by a qualified tradesperson in order to avoid a hazard. The power supply cord and plug must be replaced with a genuine replacement part available from Astivita Limited.
19. In times of low solar energy contribution, water stored in the solar tank can be heated by an electric booster consisting of an element and an automatic thermostat located on the tank. It is recommended that the electric boost be connected to a continuous electrical supply; however, if connected to an Off Peak Tariff, a night rate tariff is NOT RECOMMENDED. Note that the thermostat must only be adjusted by a qualified tradesperson.
20. **DANGER: FAILURE TO OPERATE THE RELIEF VALVE EASING GEAR AT LEAST ONCE EVERY SIX MONTHS MAY RESULT IN THE WATER HEATER RUPTURING. IT IS IMPORTANT THAT THE EASING GEAR ON THE VALVE BE RAISED AND LOWERED VERY GENTLY. FAILURE TO DO SO MAY RESULT IN THE WATER HEATER CYLINDER FAILING, OR UNDER CERTAIN CIRCUMSTANCES, RUPTURING VIOLENTLY.**
21. **IT IS NORMAL FOR SMALL QUANTITIES OF WATER (UP TO AROUND 15 LITRES IN A 24 HOUR PERIOD) TO BE RELEASED BY THE ECV OR PTR VALVE IN THE HEATING CYCLE. CONTINUOUS LEAKAGE OF WATER FROM THE VALVE MAY INDICATE A PROBLEM. IF THE VALVE DOES NOT DISCHARGE WATER WHEN THE EASING GEAR IS OPERATED, OR DOES NOT SEAL AGAIN, A SERVICE CALL SHOULD BE MADE WITHOUT DELAY. THE PTR VALVE IS NOT SERVICABLE.**
22. **THE THERMOSTAT IN THE ELECTRIC BOOST IS EQUIPPED WITH AN OVER-TEMPERATURE CUT-OUT. IF THE OVER TEMPERATURE CUT-OUT ACTIVATES, IT MUST NOT BE RESET AND THE WATER HEATER MUST BE SERVICED BY AN AUTHORISED PERSON.**
23. The amount of water heated by the electric boost is as follows:
 - a. SPS270 – 121 Litres



Astivita Limited
15 Suscatand Street
Rocklea QLD 4106
Ph: 1300 302 084

Email: service@astivita.com.au

Astivita Limited ABN 46 139 461 733

- b. SPS340 – 153 Litres
- c. SPS450 – 202 litres

24. WARNING: IF THE SOLAR SYSTEM IS NOT USED FOR TWO WEEKS OR MORE, A QUANTITY OF HYDROGEN GAS, WHICH IS HIGHLY INFLAMMABLE, MAY ACCUMULATE IN THE SYSTEM. THIS MAY BE OBSERVED AS VIOLENT 'SPLUTTERING' WHEN A HOT TAP IS OPENED INITIALLY. TO DISSIPATE THIS GAS SAFELY, IT IS RECOMMENDED THAT A HOT TAP BE TURNED ON FOR SEVERAL MINUTES AT A SINK, BASIN OR BATH BUT NOT AT A DISHWASHER, CLOTHES WASHER OR OTHER APPLIANCE. DURING THIS PROCEDURE THERE MUST BE NO SMOKING, OPEN FLAME, OR ANY ELECTRICAL APPLIANCE OPERATING NEARBY. IF HYDROGEN HAS FORMED AND IS DISCHARGED THROUGH THE TAP IT WILL PROBABLY MAKE A SOUND SIMILAR TO AIR ESCAPING.

2. HOUSEHOLDER INSTRUCTIONS – Operation and Maintenance

Warning: This appliance not intended for use by persons (including children) with reduced physical, sensory or mental capabilities, or lack of experience and knowledge.



Children should be supervised by a person responsible for their safety to ensure that they do not play with the appliance.

SOLAR SYSTEM OPERATION & ELECTRIC BOOST

When used in a solar hot water system the solar controller must be used to prevent overheating, with a top out temperature setting no more than 75deg Celsius.

Ensure that your solar hot water system is filled with water at all times. If drained at any time then the solar panels should be covered as prolonged exposure to sun without a supply of coolant water may cause damage.

DO NOT turn off the ELECTRICITY or WATER SUPPLY to the Solar Controller and Pump.

The pump and controller should be connected to a 240V 50 Hz power supply at all times i.e. throughout the entire year. Even in winter it is important that the controller is able to turn the pump ON during cold conditions to prevent panel damage due to freezing.

The controller is a differential thermostat which turns the pump on and off in response to temperature



Astivita Limited
15 Suscatand Street
Rocklea QLD 4106
Ph: 1300 302 084

Email: service@astivita.com.au

Astivita Limited ABN 46 139 461 733

signals received from a hot sensor, located in the solar panels on the roof, and a cold sensor located in a pocket at the base of the solar storage tank. The sensor cables must not be damaged or cut.

ELECTRIC BOOST

Water stored in the storage tank is heated automatically by an electric booster element which is controlled by an automatic thermostat. The booster element heats the water during very cloudy or rainy weather, during the winter months, or during periods of unusually high demand. Although it is recommended to connect the electric element to continuous power, it can be connected to an off peak tariff but NIGHT RATE OFF PEAK IS NOT RECOMMENDED as the available power may not be sufficient during inclement weather and you may run short of hot water during these periods.

The electric booster heating element is controlled by an automatic electric thermostat. The thermostat and element are mounted on the solar storage tank. The boosted water temperature is automatically controlled to the thermostat setting when the booster heating element switch is in the on position.

The thermostat is tradesperson adjustable. It has a minimum temperature setting of 60°C and a recommended maximum temperature setting of 75°C. It must only be adjusted by an authorised person. Automatic safety controls are fitted to the water heater to provide safe and efficient operation.

The electric booster element will automatically heat the water in the upper section of the tank. An isolating switch can be installed which will allow manual control however be aware that if this switch is turned off, a shortage of hot water can occur during periods of low solar radiation and **water temperatures below 60°C can give rise to bacterial breeding including Legionella bacteria. Switch not recommended for frost areas & if installed will void warranty if damage is related to Frost.**

Australian Standards therefore stipulate that this switch be left continuously on and the automatic thermostat be set to a minimum temperature of 60°C.

PRESSURE & TEMPERATURE RELIEF VALVES AND COLD WATER EXPANSION VALVE

See Solar Layout Drawings to identify these valves.

This unit must be fitted with a PTR Valve rated at 850kpa 10-12kw and installed in the port marked "RELIEF VALVE".

If the water supply pressure exceeds the rated pressure, a pressure reducing valve is to be fitted to the installation.

Never fit a Pressure and Temperature Relief Valve (PTR) or Expansion Control Valve (ECV) with a pressure rating greater than that indicated on the product-rating label.

It is normal for the ECV fitted to the cold mains water supply to dribble as either the solar panels or water heater heats water within the system. The expansion valve releases water from the system so that the system will be maintained at its design pressure.

The PTR valve fitted to the solar storage tank should not dribble during normal operation as they are



Astivita Limited
15 Suscatand Street
Rocklea QLD 4106
Ph: 1300 302 084

Email: service@astivita.com.au

Astivita Limited ABN 46 139 461 733

fitted as safety valves. If the PTR valve dribbles, operate the easing mechanism on the valve and allow water to discharge through the drain pipe. Remember this water may be HOT and ensure that the discharge does not come in contact with anyone. Release the easing lever SLOWLY and reseal the valve. If the valve is still dribbling 24 hours after resealing contact ASTIsola Service.

If no water is drawn from the system for several days in hot weather conditions the ECV on the solar storage tank may open and freely discharge water in order to discard the excess solar energy collected. This should happen only infrequently but it is considered normal operation.

If the PTR valve on the storage water heater freely discharges hot water and steam, turn off the electricity supply to the storage unit and contact ASTIsola Service.



IMPORTANT: Relief valves should be checked to be in sound working order in intervals not exceeding 5 years, or more regularly in areas subject to water deposits. Checking should include operation of the relief valve to remove any lime deposits. The PTR valve should be replaced every 5 years.

FROST PROTECTION VALVES

Frost protection valves (FRPRVA) are available from Astivita Limited and should be fitted to collectors where solar water heaters are installed in frost prone areas. Where fitted in frost areas, one frost protection valve is fitted to each panel (2 Valves required) and must be pointing downwards towards the guttering. It is normal for these valves to dribble during very cold weather. Failure to install frost protection kits in frost prone areas may void warranty should damage to collectors occur.

MAINTENANCE

Periodic - as needed (minimum six-monthly) by Owner

- Prune or remove trees or shrubs that shade the solar panels. For effective operation the panels should be in full sunlight between at least 9am and 3pm in both summer and winter. Panels which are shaded will not function correctly.
- Shading from newly erected buildings also needs to be considered and panels relocated if necessary.
-
- Check cleanliness of solar panel glass. Clean if covered in dust, grime, leaves or other build up. The panels may be cleaned with water and detergent only when the panels are cool, for example at the beginning or end of the day or during overcast conditions. If there has been little rain or if the panel is located in a dusty location it may be necessary to clean the panels more frequently. **Note.** Astivita Limited does not cover cracked or broken glass in collectors.



Astivita Limited
15 Suscatand Street
Rocklea QLD 4106
Ph: 1300 302 084

Email: service@astivita.com.au

Astivita Limited ABN 46 139 461 733

This may be covered by your household insurance policy.

- Draining and flushing the water heaters and panels must be undertaken by an authorised service agent or plumber and not by the householder due to possible high water temperatures.

WARNING!



Working on roofs should always be considered a hazardous activity; by law you must observe certain minimum safety precautions. These safety precautions are outlined in the Work Cover Code of practice "Safe work on roofs" Part 1 and 2 and in the Occupation Health and Safety Act 2011.

- Flush and reseal the PTR valve and cold water pressure ECV. This is done by raising the release lever, allowing water to flow freely and then lowering the lever and allowing the valve to reseal (this is to remove lime deposits and to verify that the valve is not blocked). Remember that the water discharging from the valves may be HOT and should not be permitted to come into contact with anyone.

Annual Service – By authorised Serviceman

Astivita Limited recommends that the Solar System be serviced annually by an ASTIsola accredited service agent. The components or parts may not be covered by ASTIsola warranty if damage to the system or parts is caused by the lack of regular maintenance.

- It is important that the PTR valves, the cold water ECV and frost valves be replaced every 5 years.
- The protective anode fitted to the solar storage tank should be checked and replaced if necessary at suitable intervals depending on water quality, but no later than every 5 years. It is recommended that Astivita Limited be contacted regarding a suitable replacement anode.
- Changing the anode at regular intervals should extend the working life of the storage tank.



Astivita Limited
15 Suscatand Street
Rocklea QLD 4106
Ph: 1300 302 084

Email: service@astivita.com.au

Astivita Limited ABN 46 139 461 733

HOUSEHOLDER FAULT FINDING

Prior to contacting ASTIsola for a service call, there are some basic checks that can be made by the householder. Please note that you will be charged by an ASTIsola service agent where the fault is not related to manufacture or failure of a part or out of warranty.

NOT ENOUGH OR NO HOT WATER

If the collectors are shade-free, the weather is fine and warm and the solar storage tank contents are definitely cold, the circulating pump should operate and the return connection become warm or hot. Please note that the pump is almost silent and vibration-free in operation. Check the following:

1. Is there 240 volts at the power outlet? Is there a blown circuit breaker, RCD or fuse?
2. Is the pump plugged into the controller? The pump and controller are located under the plastic terminal box cover on the storage tank.
3. Are the sensors plugged into the correct sockets in the controller?
4. Are the sensors correctly fitted into the sensor pockets on the tank and collectors?
5. Has all air been purged from the system?
6. Has your hot water usage changed?
7. Is the thermostat setting sufficient to recover from hot water usage?

PRESSURE AND TEMPERATURE RELIEF (PTR) VALVE LEAKING

It is usual for a pressure and temperature relief valve to release a small quantity of water during the heating cycle; up to around 15 litres over a 24 hour period is acceptable. If the discharge is noticeably more than this, contact an ASTIsola service technician.

COLD EXPANSION CONTROL VALVE (ECV) LEAKING

The ECV may discharge a small amount of cold water to prevent the PTR valve from potentially discharging water that has been heated, thereby saving energy. This is normal.

3. SOLAR TANK INSTALLATION



Astivita Limited
15 Suscatand Street
Rocklea QLD 4106
Ph: 1300 302 084

Email: service@astivita.com.au

Astivita Limited ABN 46 139 461 733



INSTALLER – PLEASE NOTE THE FOLLOWING

- 1. THIS WATER HEATER IS NOT SUITABLE FOR POOL HEATING**
2. All work associated with the installation of this water heater must be carried out by properly trained and accredited tradespersons and be strictly in accordance with relevant Australian Standards including AS/NZS 3500.4 and AS/NZS 3000, local, State and Federal Regulations including, but not limited to, Occupational Health, Safety and Welfare Regulations (OH&S)
3. If this installation is taking place in an area subject to frost conditions or freezing conditions (below 5° Celsius), the FRPRKI Frost protection Kit containing two frost protection valves should be installed on the panels.

The solar water heater tank should be installed in close proximity to the most frequently used hot water outlet and its position chosen with safety and service in mind. Other considerations include the position of the solar tank with respect to the solar collectors as heat loss can occur in the pipes, and copper pipe length should not exceed 20 metres (for 2 panel systems). Also consider servicing (the water heater must be accessible without the use of a ladder or scaffold and the anode, PTR valve, thermostat and booster element must be able to be removed) and nameplate data must be able to be read. Other considerations include:

- 
- Electrical supply requirements for the pump and controller
 - Weight of the heater filled with water
 - Dimensions of the heater and size and location of connection points
 - Water supply pressure limitations

CLEARANCE

Allow adequate room to work with tools. A minimum of 25mm clearance around the water heater is required. An additional 30mm is required for relief valve removal, 80mm for access cover removal and 400mm for element removal. You should be able to read the information on the rating plate and all informative labelling.

Adequate provision must be made to dispose of any water escaping from heater or adjacent plumbing that might result in damage to property.

The water heater must be connected in such a way that:

- Space is allowed for the removal of the heating element.
- Space is allowed for the removal and replacement of the anode.
- The pump & Controller is accessible for servicing.
- Complete removal of the unit can be easily effected if necessary



Astivita Limited
15 Suscatand Street
Rocklea QLD 4106
Ph: 1300 302 084

Email: service@astivita.com.au

Astivita Limited ABN 46 139 461 733

CONFINED SPACES



If the thermostat fails the unit may produce excessive steam.

It is strongly recommended that the heater should be installed in a well-ventilated space to avoid condensation build up.

If installed in confined areas, make provision for Service Access.

Vent safely to open air and carry hot water overflow pipework to drain.

FOUNDATION

To ensure adequate ventilation, position the unit on an approved support base on a concrete slab or other approved foundation (See figure below). Ensure adequate drainage to prevent water ponding around the base of the tank when exposed in wet locations. **(Failure to adhere may void warranty).**

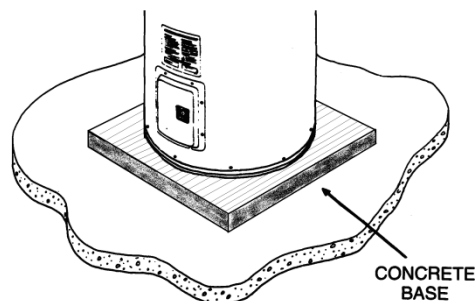

Alternative forms of water heater bases are acceptable providing they allow for adequate ventilation and drainage.

Attention is drawn to the weight of the water heater tank when full (up to approximately 600kg depending on model) and the installer should ensure the base and footings are substantial enough to avoid subsidence etc.

WATER SUPPLY

If the water heater is installed to a tank water supply, a minimum 200kPa water supply pressure must be available or a pressure pump must be installed to allow operation of the system. **(An inline serviceable water filter fitted prior to water supply to the Hot Water Storage Tank is recommended in areas of poor water Quality). (Maximum inlet water pressure of 500kpa)**



Astivita Limited
15 Suscatand Street
Rocklea QLD 4106
Ph: 1300 302 084

Email: service@astivita.com.au

Astivita Limited ABN 46 139 461 733

This water heater has been constructed to meet water quality conditions in most Australian water supply locations. However, harsh water quality does exist in some locations and, if in doubt, contact your local council or water supplier. Only potable water should be used in this water heater. If you are unsure of the water chemistry in your area, you may find additional information by contacting your local water supply authority.

Anode: The anode in your water heater is sacrificial, however it is designed to protect the vitreous enamel lined cylinder in most public reticulated water supplies for five years after which time it should be replaced as part of annual service. However it is important to understand that many water supplies can exhibit chemical qualities that are not suitable for the standard anode supplied with this water heater. Where the Total Dissolved Solids (TDS) is greater than 600mg/L or less than 40mg/L, the installed anode may be unsuitable for use to protect your water heater. In these circumstances, a plumber or authorised service person should be contacted to fit the correct anode. Different anodes are available in these situations to protect the vitreous enamel lined tank. Please note that warranty becomes void if the TDS value exceeds 2500 mg/L.

The **Saturation Index** is a measure of the water's corrosiveness. Corrosion may result in early failure of copper parts such as solar collectors and copper sheathed electric components. Water is considered corrosive should the saturation index be below -1.0. Scaling, which is the build-up of calcium carbonate in the tank, can occur where the Saturation Index is above +0.4. In these instances where the Saturation Index exceeds +0.4, ensure the expansion control valve (ECV) is fitted according to instructions contained within this manual. Should the saturation Index exceed +0.8, a low Watts density element must be fitted.

Water heaters installed in locations where incorrect anodes are fitted due to high or low TDS or where the water is corrosive or considered scaling will not be covered by this warranty.

SOLAR CONTROLLER AND PUMP OPERATION



The Aestiva Solar Controller and Grundfos Pump, supplied with this Solar Water Heater, are enclosed within a UV Resistant ABS plastic enclosure which is designed to house these components and protect them from harmful UV radiation. This Pump/Controller assembly is fitted onto the side of the tank directly above the Cold Water Inlet using 8 off 4mm screws provided in nut-serts located in the tank.

The control unit turns the pump on and off in response to temperature signals received from a hot sensor located in the solar panel's hot water outlet fitting on the roof top, and a cold sensor located at the entry to the storage tank. It is crucial that these sensors and leads are not damaged or cut during or subsequent to installation.

Note that after 2 hours of operation of the pump, it will automatically switch off for five minutes before resuming to prevent any possible cavitation of the pump.

The controller incorporates an LCD display that can easily be read to identify the various sensor temperatures and error modes (shown in bold below).

Temperature Probe Turn On (**Pump On Temp**) and Turn Off (**Pump Off Temp**) temperatures are as follows:

"Pump On Temp": 8°C Differential (ΔT) between Panel Sensor temperature and Tank Temperature Sensor (panel sensor hotter than tank sensor).

"Pump Off Temp": 2°C Differential (ΔT) between Panel Sensor temperature and Tank Temperature Sensor.



Astivita Limited
15 Suscatand Street
Rocklea QLD 4106
Ph: 1300 302 084

Email: service@astivita.com.au

Astivita Limited ABN 46 139 461 733

The Controller will also prevent the pump from circulating water to the panels should the tank temperature, measured at the Tank Temperature Sensor become too high. Temperature setting to protect the tank is as follows:

“Top Out Temp”: 75°C measured at the tank mounted sensor will de-activate the pump to protect the vitreous lining of the steel tank.

Freeze protection is also a standard function of the controller. Where the panel temperature measured at the Panel Temperature Sensor approaches freezing, the pump will activate and circulate heated tank water to the panels until the panel temperature rises and prevents against frost damage. Temperature settings are as follows:

“Protect On Temp”: 3°C measured at the roof top sensor will activate the pump.

“Protect Off Temp”: 5°C measured at the roof top sensor will de-activate the pump

Note that when cold conditions prevail overnight, this frost protect mechanism may switch the pump on and off several times to protect the panels, potentially resulting in reduced hot water being available in the morning.

The sensor leads are extra low voltage but must to be encased in 20mm PVC conduit and secured with conduit saddles to ensure they remain undamaged.

The hot sensor (long lead) should be dry and pushed to the bottom of the long hot sensor pocket on the top left hand corner of the solar panel. A clip on the sensor probe port is provided to secure the sensor lead.

The cold sensor (short lead) is to be fitted dry into the short cold water sensor pocket at the cold water entry to the solar storage tank. Refer to the respective layout diagram supplied with the Solar Storage Tank.

Controller Error Codes

The LCD display will normally display the Lower “L” tank sensor temperature and the Roof-top “R” sensor temperature as follows:



Astivita Limited
15 Suscatand Street
Rocklea QLD 4106
Ph: 1300 302 084
Email: service@astivita.com.au

Astivita Limited ABN 46 139 461 733

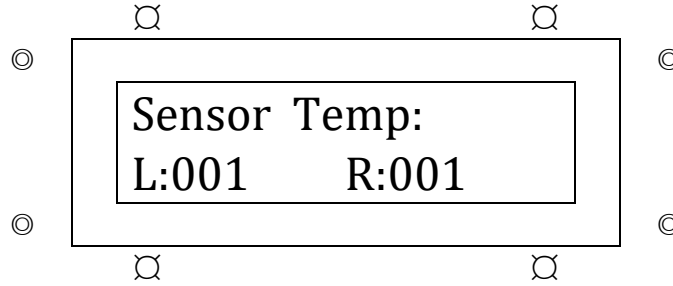

In event of a tank sensor failure, an error code will be shown on the display and 4 LED lights (2 green and 2 red) will become visible as follows:

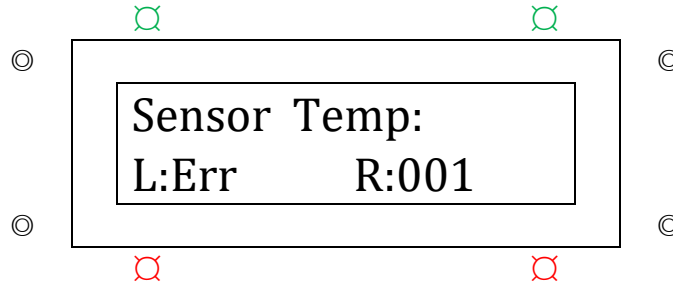

Similarly, when errors occur on roof top or both sensors, the display will indicate as follows:

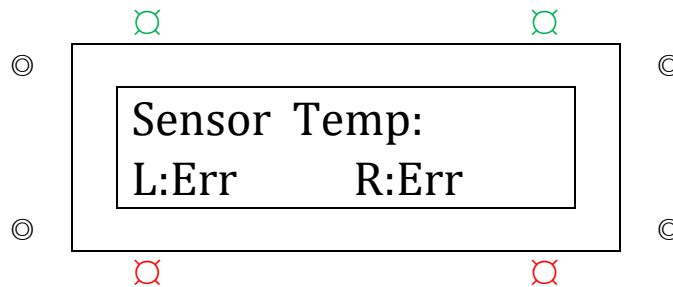

Astivita Limited ABN 46 139 461 733

Basic Controller Functions

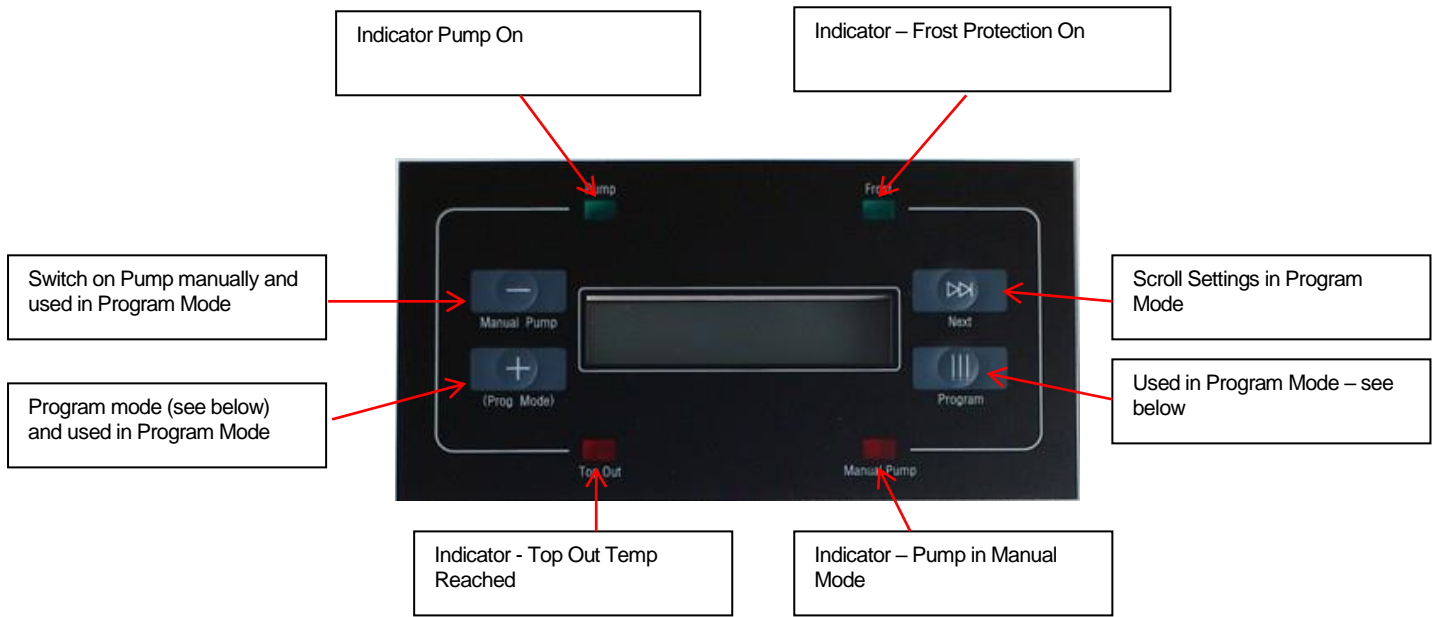

Programming the Controller

NOTE: THE CONTROLLER IS PRE-SET AT THE FACTORY TO OPERATE AT OPTIMAL SETTINGS FOR MOST SITUATIONS. ANY ACCESS TO THE PROGRAM MODE AND CHANGE TO FACTORY SETTINGS MUST BE DONE BY A QUALIFIED AND AUTHORISED PERSON. RANGE OF SETTINGS AVAILABLE ARE AS FOLLOWS:

SETTING	Factory Setting (°C)	Minimum Setting (°C)	Maximum Setting (°C)
Pump On Temp	8	0	90
Pump Off Temp	2	0	90
Top Out Temp	75	0	90
Protect On Temp	3	0	90
Protect Off Temp	5	0	90



Astivita Limited
15 Suscatand Street
Rocklea QLD 4106
Ph: 1300 302 084

Email: service@astivita.com.au

Astivita Limited ABN 46 139 461 733

Access to the Program Mode is as follows:

1. Press and hold down “**Next**” and “**Program**” keys
2. Then, press and hold down “(**Prog Mode**)” key whilst holding down the “**Next**” and “**Program**” keys for approximately 3 seconds. Red and Green LED’s will flash.
 - a. “**Pump On Temp**” appears – Value = 008 (factory pre-set). Remove fingers from keys.
 - b. “**Pump On Temp**” can be increased or decreased using the “+” and “-” buttons
 - c. Following any changes, the program may either be exited by pressing and holding down the “**Program**” key for around 3 seconds or access next Setting “**Pump off Temp**” by pressing the “**Next**” key. The same method applies to accessing all five settings available.
 - d. When all settings are set to desired level, press and hold the “**Program**” key for around 3 seconds. All settings will be retained and “**Set Finish Rebooting**” will briefly appear before returning to sensor temperatures.

MANUAL PUMP Key

When pressed (not in Program Mode), this key activates the pump manually, over-riding the pre-set settings of the controller. “Pump” and “Manual Pump” LED’s will glow. If left on, the pump will run for 2 hours and then switch back to PUMP AUTO.



DO NOT turn off the ELECTRICITY or WATER SUPPLY to the Solar Controller and Pump. Including pressure pumps for water supplied to Dwelling from water tanks.

Note: Panel warranty does not cover damage caused by frost or freezing where:

- The solar controller and or pump are not operating;
- Frost protection valves have not been fitted;
- The mains water supply to the system has been turned off; or
- The mains cold water supply to the system freezes because it is not insulated.



Astivita Limited
15 Suscatand Street
Rocklea QLD 4106
Ph: 1300 302 084

Email: service@astivita.com.au

Astivita Limited ABN 46 139 461 733

PIPEWORK, VALVES AND FITTINGS

Valves and fittings for connecting the solar panels on the roof and the storage tank are supplied. The temperature of the water at the outlet connection on the panels may reach 150°C or more and therefore only copper pipe can be used between the panels, storage tank and boosting heater.

Class B copper pipe should be used and the runs should be as short as possible to reduce heat losses.

The pipes **MUST** be lagged using thick-walled foam of at least 19mm thickness, RO.6 and should be weather proofed and UV stabilized.

If insulation is not UV stabilized, it must be protected by a suitable UV resistant paint.

Pre-cut pieces of insulation and cable ties are provided to insulate the pipework fittings. The areas to be insulated are: inlet pipework fittings to the panel, the outlet pipework fittings, and on 2 & 3 panel systems the joiners between the panels. These fittings must be insulated to protect them from freezing in cold areas. Warranty may be void if not fitted. Refer to the Solar Panel Layout drawings for location and installation detail. Water may drip from the pipe of the pressure-relief device. This pipe must be left open to the atmosphere

MOUNTING KITS

Note: The copper pipework and specified insulation is to be supplied and fitted by the installer.

The solar water heater is equipped with two Plumbing Mounting Kits as follows:

1. **Ground Kit** – Ground Mounting Kit supplied as part of the Solar Water Heater Tank installation package.
2. **Roof Kit** – Roof Mounting Kit supplied as part of the Solar Collector installation package.
(Standard kit supplied & referred to in this manual **Cannot** be used for Cyclonic Installations. For Cyclonic Installation please contact Astivita for alternate Installation kit.)



Astivita Limited
 15 Suscatand Street
 Rocklea QLD 4106
 Ph: 1300 302 084

Email: service@astivita.com.au

Astivita Limited ABN 46 139 461 733

Both kits are designed to provide the installing plumber with all parts required for a normal installation. Additional components required for installation are to be supplied by the installing plumber.

The following items are contained within the Ground Mount Kit. Refer to section below entitled “Solar Collector Installation” regarding componentry for Roof Mount Kit.









The Ground Kit Contains:

- Glinki2 Brassware and Valves (Excluding PTR Valve which is contained in the water heater tank packaging)
- Installation Manual including commissioning check list to be completed and passed to the homeowner
- Pump and Controller.
- Stainless steel screws for mounting pump and controller may be found in GLINKI2 kit.





GLINKI2 – Ground Mounting Kit Components

Codes: S'Power (AVG)	Image	Quantity	Instructions
HWP 652 (BFEQuickie15) Diagram item 10		2	Used for Hot Water Outlet and Solar Return connection
HWP 681 (BFP15MI)		1	Used for connection to unused port on 4-Way Tee
HWP 665 (BFS15) Diagram Item 3		4	4 required 1. Connection of Item 7 – ECV Valve 2. Connection of Item 11 – Flow Valve 3. Connection of Item 2 PLV 4. Connection of Item 10 – Solar Return
HWP 656 (BFT15C15C15C w 1 Nut & Olive) Diagram item 4		1	Connection of 500kPa PLV to 4-Way Tee
HWP 656 (BFT15C15C15C w 2 Nuts and Olives) Diagram items 4/6		1	Tee off for ECV Valve Refer to installation diagram for positions

Astivita Limited ABN 46 139 461 733

HWP 661 (601074 – 15MI Thermowell)		1	15mm Thermowell Sensor Port on 4-Way Tee (Item 5)
HWP 655 (BFTQuickie15) Diagram item 5		1	4-Way Tee for connection to Cold Water Inlet (Flow)
HWP 670 (BFU15MI15C) Diagram item 8		3	Drain Line unions for ECV Valve, PTR Valve and Solar Return Pipe from Collectors
HWP 675 (BFU25Q15C) Diagram item 12		1	Pair of Pump Connection Unions
HWP 870 (ECV15-700) Diagram item 7		1	700kPa Expansion Control Valve (ECV)
HWP690 (FC15FL – 175mm) Diagram Item 14		1	175mm Stainless Steel Flexible Coupling
HWP 685 (FM15-1.4) Diagram item 11		1	Flow Meter 1.4L/Min (Installer - Set to 1.0L/Min on installation)
HWP 866 (NRIBVS – 15C) Diagram item 1		1	Non-Return Isolating Valve with Strainer and Insulation
HWP 867 (NVHT-15F-15C w Nut and Olive) Diagram item 13		1	15mm High Temperature Non-Return Check Valve. Install on load side of Pump & Controller. (Note direction of Flow)

Astivita Limited ABN 46 139 461 733

HWP 868 (NVHT-15F-15C without Nut and Olive) Diagram item 13		1	15mm High Temperature Non-Return Check Valve. Install on Solar Return line. (Note direction of Flow)
HWP 855 (PLV15-500FM) Diagram item 2		1	500kPa Pressure Limiting Valve installed after Trio- Valve (Item 1)
HWP 860 (TVA15CHP) Diagram item 9		1	High Performance Tempering Valve 15mm with Insulation
HWP 275 (MSKM15MM)		1	4 off M4 and 4 off M6 304 Grade S/Steel Screws and washers for mounting of Base Plate and Cover of Pump and Controller Assembly to Tank Outer Casing. (Note Nut-serts provided on Tank Case for ease of mounting).
PTR VALVE SUPPLIED WITH THE SOLAR TANK 850KPA 10-12KW		1	TO BE INSTALLED INTO THE TANK PORT MARKED "RELIEF VALVE". 

Astivita Limited ABN 46 139 461 733

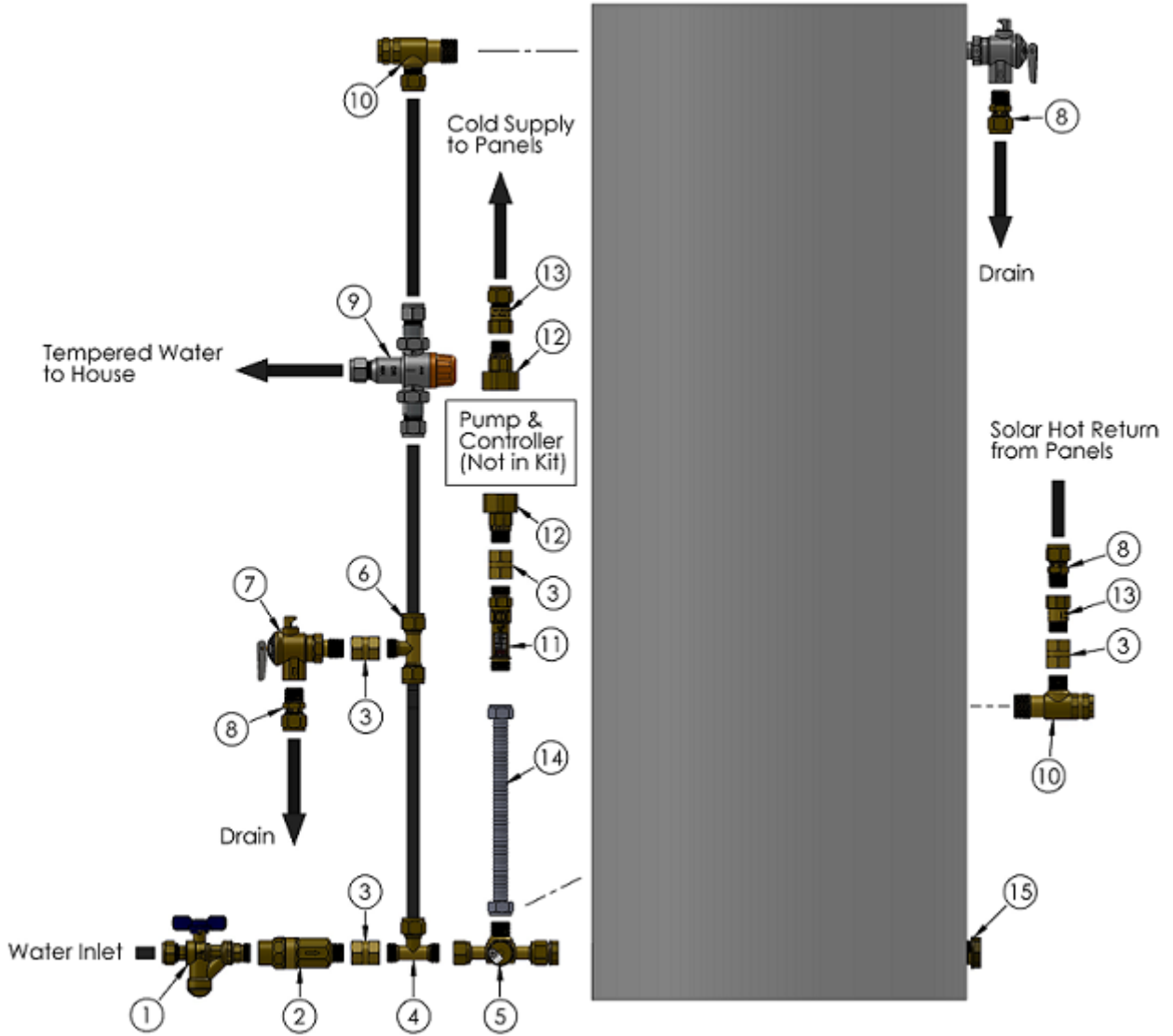

GLINKI2 Kit Installation Diagram

4. SOLAR COLLECTOR INSTALLATION

The Roof Kit Contains: Collector Racking System as detailed below

- Installation Instructions for Mounting Collectors and Racking
- STAKITGL2 – Brass ware for collectors

(Standard kit supplied & referred to in this manual **Cannot** be used for Cyclonic Installations. For Cyclonic Installation please contact Astivita for alternate Installation kit.)



INSTALLATION OF COLLECTOR RACKING SYSTEM

Important Information. Installer please read the following information carefully before installing the solar collector racking system.

The following Items are Included in the racking system kit:

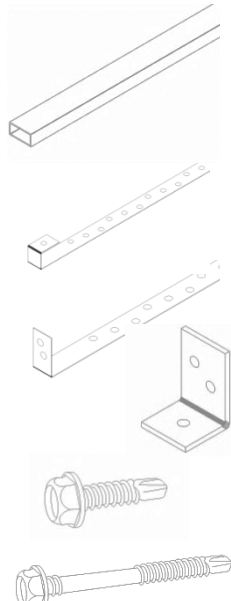
Solar Water Heater Collector Racking System			2 Panel	3 Panel	
Code	Description	Illustrations	SWHRS - 2P QTY	SWHRS - 3P QTY	
ALBX26	2.6m Al Rail 38 x 25 x 2.0 RHS - 6063-T5		1	1	
ALBX18	1.8m Al Rail 38 x 25 x 2.0 RHS - 6063-T5				
ALBX22	2.2m Al Rail 38 x 25 x 2.0 RHS - 6063-T5			1	
LOBR	Lower Mounting Bracket - S/Steel			4	6
UPBR	Upper Mounting Bracket - S/Steel			4	6
MOBR	Aluminium Mounting Feet - 6063-T5			4	6
SCMET25	M6 x 25, C4 Coating EPDM - 6-030-3308-3C4		20	30	
SCMET65	M6 x 65, C4 Coating EPDM - 6-030-3307-2C4		8	12	



Astivita Limited
15 Suscatand Street
Rocklea QLD 4106
Ph: 1300 302 084

Email: service@astivita.com.au

Astivita Limited ABN 46 139 461 733



NOTE: Ensure the mounting surface is strong enough to support the collectors. Most roofs can support the panels, but if unsure consult a structural engineer.

Both 2-Collector and 3-Collector models are available utilising high performance European collectors. Collector sizes and weights are provided below:

- a) 2 Collectors are 2.4m wide x 2.04m high. (88kgs total, filled with water)
- b) 3 Collectors are 3.6m wide x 2.04m high. (132kgs total, filled with water)

To achieve maximum solar performance, the solar collectors should be installed facing as close to North as possible. The following are guidelines for the installation of solar collectors:

- Solar collectors should be positioned to face the equator which is North facing in Australia. The further away from North, the greater the loss in solar efficiency.
- The inclination of the solar collectors should be within 10% either side of the local latitude angle. For example, the latitude of Brisbane is 27^o South so the inclination of the solar collectors should be approximately 24 to 30 degrees.
- Solar collectors should be free from shading by trees (should be checked regularly) or nearby buildings or other structures.

Astivita Limited ABN 46 139 461 733

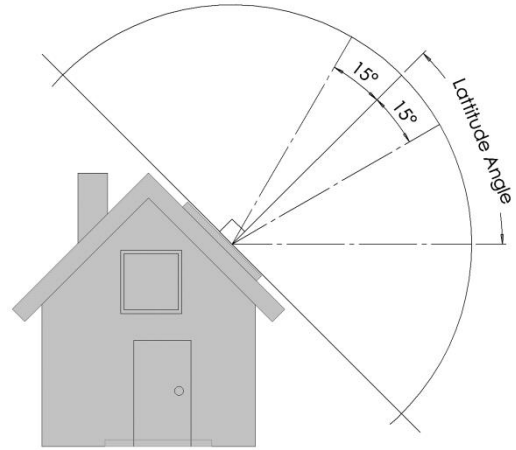
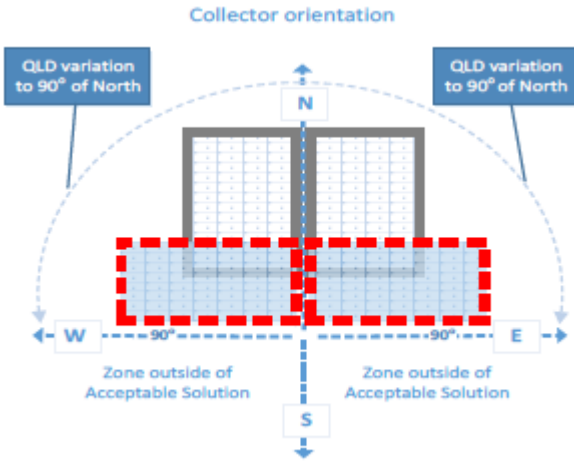

Queensland Plumbing and Wastewater Code

Part 7—Installation of solar heated water systems

	PERFORMANCE CRITERIA		ACCEPTABLE SOLUTIONS
P1	The collectors for a solar <i>heated water</i> system must be installed to maximise solar gain and minimise energy loss.	A1	<ol style="list-style-type: none"> The collectors for a solar <i>heated water</i> system must be installed in accordance with AS/NZS 3500.4:2015, subject to A1.2 of this Part. For applying AS/NZS 3500.4:2015, the reference in clause 6.5.1.2 of the standard to '45°' is taken to be a reference to '90°'. Note: Clause 6.5.1.2 provides that collectors must be installed so they face no more than 45° east or west of true north.

It is proposed through the Queensland Plumbing and Wastewater Code to include a specific variation to the deemed to satisfy requirement of AS/NZS3500,4: 2015 clause 6.5.1.2. This variation now allows the installation of collector panels associated with a solar hot water system to be installed to an orientation of not more than 90 degrees east or west of true north.

Step 1.

When installing the solar collectors, it is important that sufficient clearance of approximately 0.5 metres or greater be left between the lower edge of the roof and the bottom rail of the solar collector installation



Astivita Limited
15 Suscatand Street
Rocklea QLD 4106
Ph: 1300 302 084

Email: service@astivita.com.au

Astivita Limited ABN 46 139 461 733

Locate the stainless-steel lower mounting brackets (LOBR) and the aluminium rail within the racking kit.

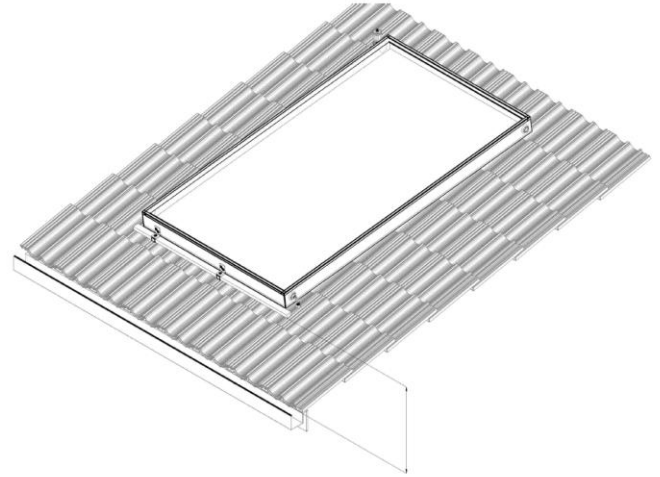

0,5m or
greater

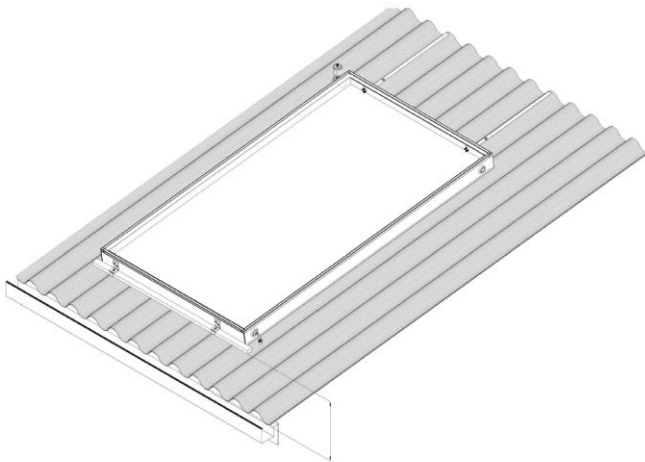

Step 2A. – Metal Roofs

Locate the straps on the roof with the U-Cup on the strap upright and facing up the roof line. These straps can be secured in a horizontal plane using SCMET65 screws provided and screwed directly into the wood or steel roof batten.

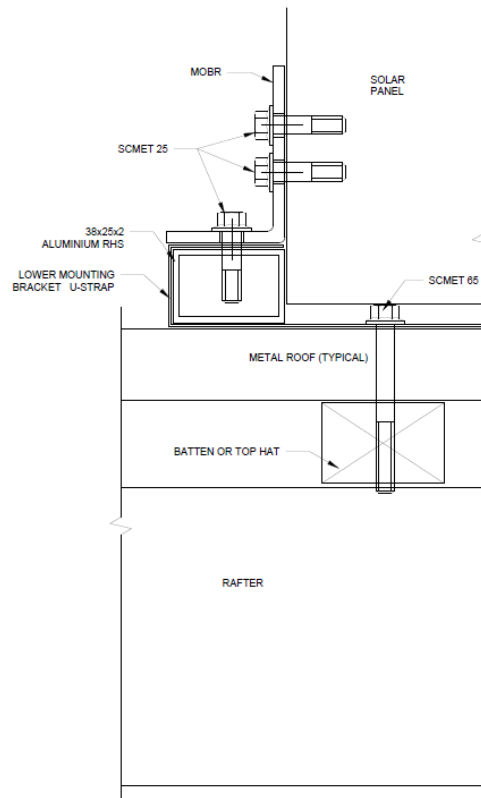

Step 2B. – Tile Roofs

Carefully remove roof tiles to locate roof trusses for fastening the straps.

Shape the straps around the roof tiles with the U-Cup upright and facing up the roof line above the tile. These straps can be fixed directly to the roof trusses using the SCMET65 screws provided. Ensure all straps are in one horizontal plane across the roof line.

Astivita Limited ABN 46 139 461 733

Carefully replace roof tiles and replace any damaged tiles.

- NOTE: 1. ANGLE θ THAT LOBR MAKES WITH TILE AND RHS IS GOVERNED BY THE TILE PROFILE.
 2. LOBR SHOULD BE FASTENED AS CLOSE AS PRACTICAL ON TRUSS / RAFTER TO POINT OF ENTRY UNDER TILE.
 3. LENGTH OF UNSUPPORTED TILE BRACKET BETWEEN RHS AND TILE SHOULD BE MINIMIZED WETHER POSSIBLE FOR INCREASED STRENGTH.

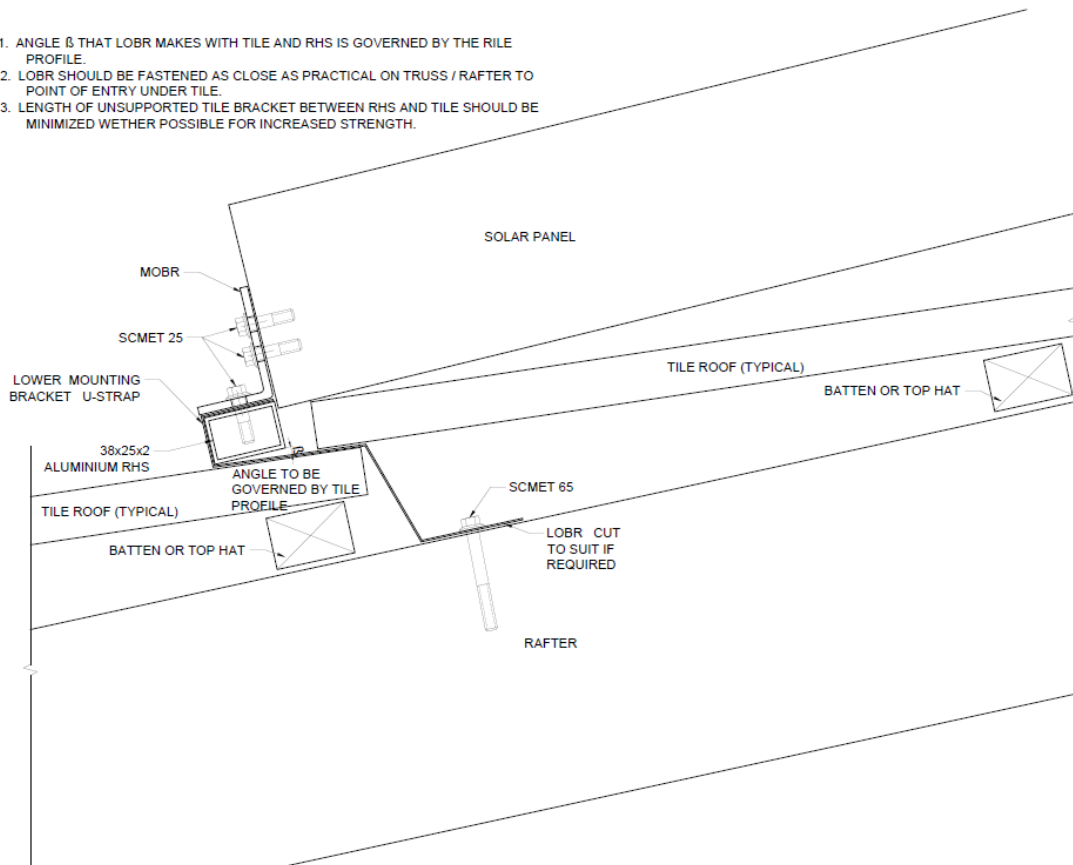



Astivita Limited
15 Suscatand Street
Rocklea QLD 4106
Ph: 1300 302 084

Email: service@astivita.com.au

Astivita Limited ABN 46 139 461 733

Step 3.

Lower the aluminium rail into the U-Cups of the mounting straps.

Locate the mounting feet (MOBR) from the racking kit and screw the mounting feet into the rail, securing the top of the U-Cup between the mounting feet and the rail. Secure using SCMET25 screws provided.

Step 4.

The first panel can now be carefully lifted to the roof top in accordance with OH&S regulations.

Following installation of the interconnecting barrel unions to the initial panel, the bottom of this panel can be secured to the mounting feet (MOBR) using the SCMET25 screws provided. The first panel is now secured into position and fastened to the roof by two mounting straps.

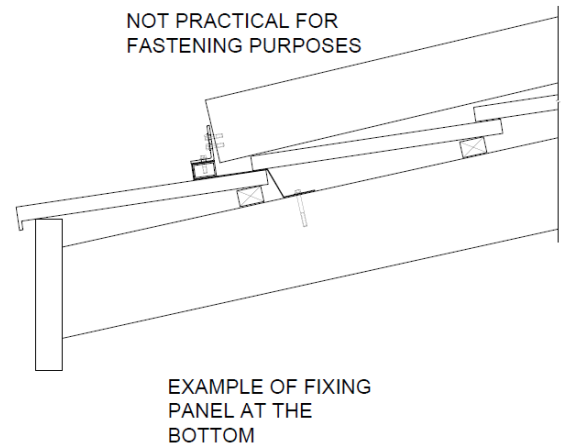



Astivita Limited
15 Suscatand Street
Rocklea QLD 4106
Ph: 1300 302 084
Email: service@astivita.com.au

Astivita Limited ABN 46 139 461 733

Repeat this process with the second panel and tighten the barrel unions to ensure no leakage will occur when commissioning the system.

NOTE: LENGTH OF UNSUPPORTED TILE BRACKET BETWEEN PANEL AND TILE SHOULD BE MINIMIZED WHETHER POSSIBLE FOR INCREASED STRENGTH

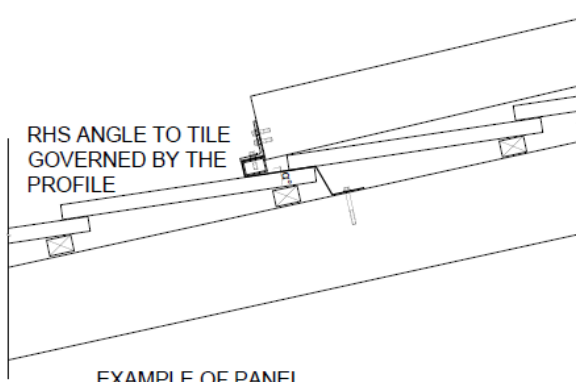

EXAMPLE OF PANEL FIXING AT THE BOTTOM

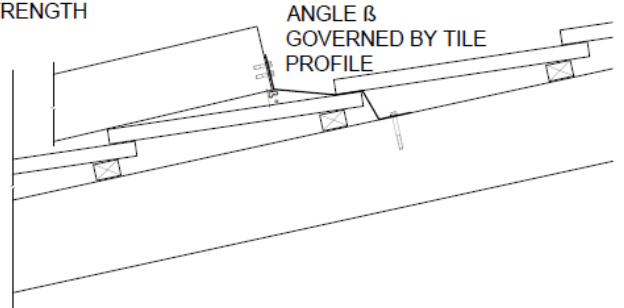

EXAMPLE OF PANEL FIXING AT THE TOP

Astivita Limited ABN 46 139 461 733

Step 5A. – Tin Roofs

Identify the stainless steel upper mounting brackets (UPBR) from the racking kits. These straps are secured to the top of the panel using the SCMET25 screws and fastened to the roof directly into a timber or steel batten using the SCMET65 screws provided.

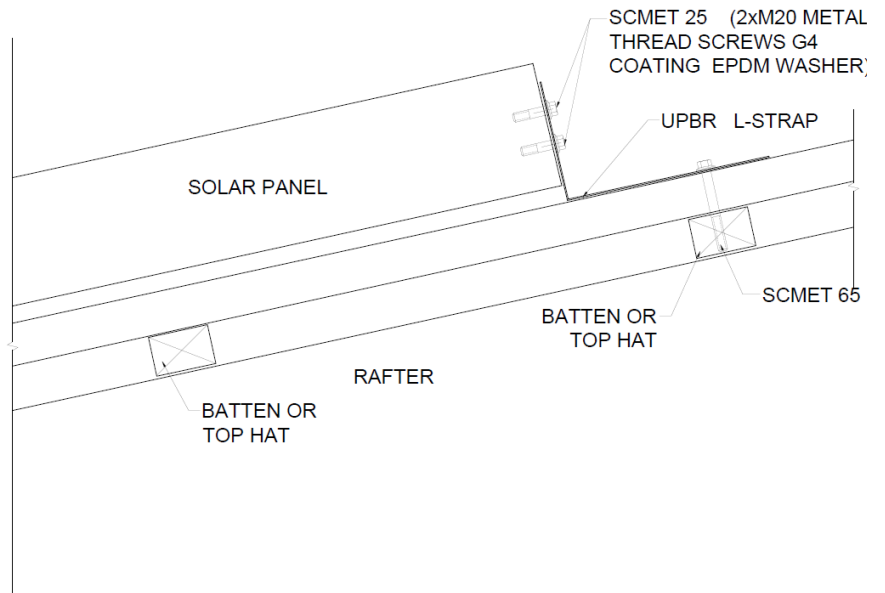

Astivita Limited ABN 46 139 461 733

Step 5B. – Tile Roofs

Carefully remove tiles to locate trusses to secure straps. Fasten the straps to the panels at these locations using the SCMET25 screws provided. Shape the straps around the roof tiles and secure to the roof truss using the SCMET65 screws provided.

Carefully replace roof tiles and replace any damaged tiles.

Each panel is now secured with 4 stainless-steel straps to the roof structure and ready for all plumbing connection to be undertaken utilising the STAKITGL kit provided with the panels.

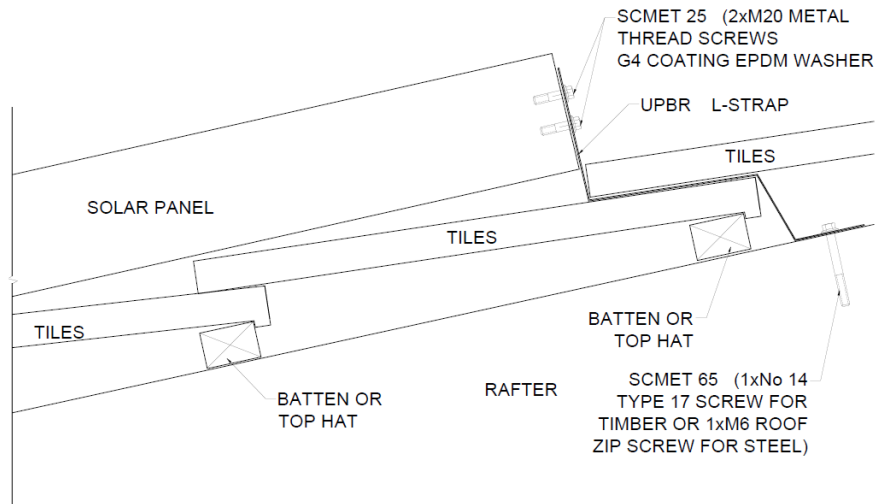



Astivita Limited
15 Suscatand Street
Rocklea QLD 4106
Ph: 1300 302 084





Email: service@astivita.com.au

Astivita Limited ABN 46 139 461 733

STAKITGL2 – Collector Plumbing Roof Mount Kit

The STAKITGL2 Plumbing Roof Mounting Kit is supplied with the solar collectors for installation when the collectors are installed. The kit does not include Frost Protection Valves as standard. The Frost Protection Valves (FRPRVA) are available as an accessory for use in frost prone areas.

Components contained within the STAKITGL2 include:

Codes: AstiVita (AVG)	Image	Quantity	Instructions
HWP662 (BFAVT20R)		1	AVG Custom Sensor Fitting. Insert Roof Top Sensor to end of pipe when installed. Comes with Insulation Glove. Fit hot water return to tank.
HWP651 (BFE20MI15CQIK)		1	20MIx 15C Elbow. Cold Water Inlet to bottom RHS of Collector with Insulation Glove.
HWP682 (BFP20MI)		2	20mm Male Brass Plugs for top-right and bottom-left FM ports on Hot Water Collectors.
HWP672 (BFU20R25Q20R)		2	20MI x 20MI Brass Barrel Union with Insulation Glove for connection of the solar collectors.
AEHT-10		1	Air vent comes with Insulation Glove.

NOTE: Details of STAKITGL2 components shown above are for two-panel configurations. Three panel kits (STAKITGL2/3) are also available on request.

Astivita Limited ABN 46 139 461 733

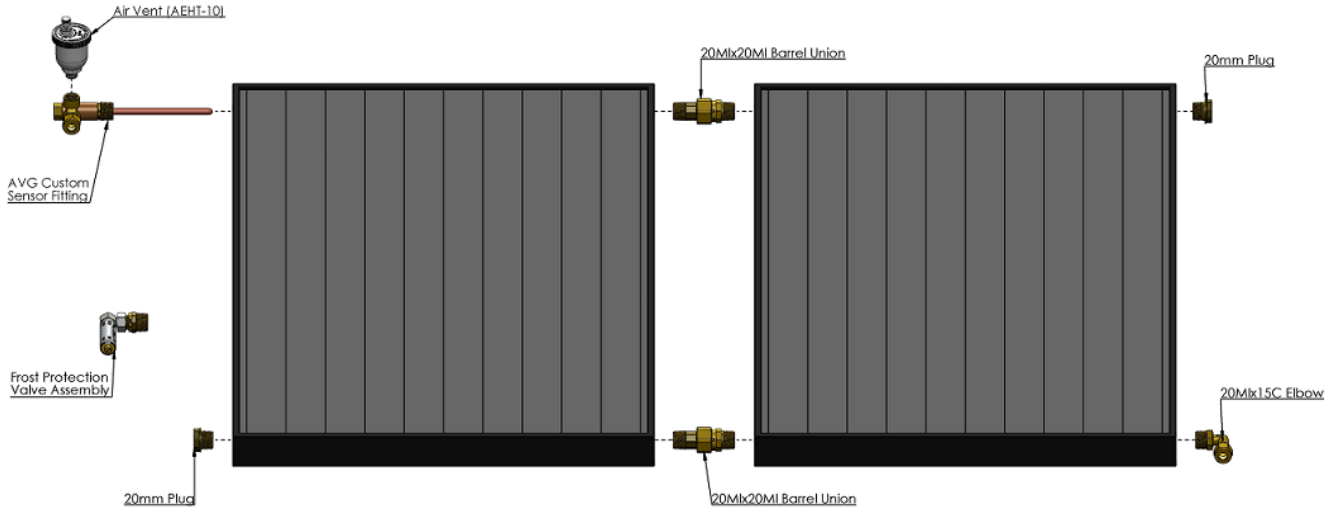

STAKITGL2 Installation Diagram

FROST PROTECTION VALVES

ASTIsola can provide the Frost Valves. These valves are required to be installed in frost prone areas or areas subject to freezing (below 5°C) and must be installed facing downwards (one per panel). The valve must not contact the roof. During frosty conditions these valves open and allow a slow flow of water through the panels. They will automatically close when the water temperature rises. They provide backup for the freeze protection facility on the controller in the event of power failure. Do not use thread sealants to connect the frost valves; they must be fitted using the sealing washer supplied with the valve. Note: Thread sealants may cause problems with the operation of the valve. See instructions supplied with frost valves for recommended installation relating to “Dead Legs” with installation is advisable for avoiding any risk of damage of the device caused by overheating from the solar collector, in case of stagnation conditions.

Frost Protection Valves	FRPRVA
--------------------------------	---------------

Product Code	Description	Qty.
FRPRVA	Frost Protection Valve	2 Required





Astivita Limited
15 Suscatand Street
Rocklea QLD 4106
Ph: 1300 302 084

Email: service@astivita.com.au

Astivita Limited ABN 46 139 461 733

4. FILLING AND COMMISSIONING THE SYSTEM

Do not turn on electric power until the whole system has been filled with water and a satisfactory Megger reading is obtained by a qualified person.

SOLAR STORAGE TANK AND WATER HEATER

Follow instructions supplied with the heater. Note that it is necessary to provide a properly drained safe-tray under heaters located where leakage may cause damage.

When locating the water heater, ensure the installation does not compromise the structural integrity of the building.

Note: A Tempering Valve must be fitted in accordance with Australian Standards and other State and Council regulations.

Turn on a hot water outlet tap, preferably the one furthest from the heater. DO NOT purge through the PTR valves. Open the mains cold water supply valve so that air is displaced from the water heater and replaced with water. The hot water outlet tap should be left on until the water flowing from it flows steadily without spurts. Turn off the hot water tap and allow the system to pressurize. Check the system for leaks. Repair if required.

SOLAR PANELS



The solar panels must only be filled when they are cold, so it is important to ensure that the panels are fully covered for a suitable time beforehand. Filling hot panels may cause injury by scalding.

Turn on the mains water supply and ensure the water heater is full of water and all of the hot taps are turned off. Turn on the circulating pump either by the manual override or by plugging it directly into a power point-

Note. Air in the system will prevent circulation so it is important that all air be removed from the solar panel circuit. The air bleed valve installed at the top of the panels needs to be checked to ensure the Air Relief valve top is opened and that when the pump operates the air valve seals properly when the pump is operating. This can be done by listening to the valve to ensure air is not entering the pipe work. Let the pump run for 3-5minutes if the air is still bubbling into the tank at this stage the valve may not be sealing or there is another fitting requiring tightening. Allow the system to pressurise. Check for leaks and rectify if required.

Remove covers from solar panels.



Astivita Limited
15 Suscatand Street
Rocklea QLD 4106
Ph: 1300 302 084

Email: service@astivita.com.au

Astivita Limited ABN 46 139 461 733

WARNING – on a sunny day, if the solar panels are not covered during this operation, the water flowing from the air bleed valve can be extremely hot causing steam and possible scalding. Ensure sufficient precautions are taken to prevent injury to nearby persons.

SOLAR PUMP AND CONTROLLER

Ensure that the hot and cold sensors are plugged into the correct sockets at the tank inlet connection and the top hot outlet of the solar collectors.

Ensure that the pump is correctly plugged into the Solar Controller power outlet.

Plug the Solar Controller into the weatherproof (where required) mains power outlet and switch on.

If the weather is fair, the return pipe from the panels will become warm. Please note that the pump is very quiet and vibration free in operation.

If the weather is cool and cloudy, it may be necessary to cool the cold sensor probe to make the pump run. Alternatively, temporary connection of the pump to mains power will enable a test run. Be sure to reconnect it to the Solar Controller after testing.

Note: If the pump is not capable of purging air from the system, all air must be purged manually from the highest point at the panels.

HOW TO TURN OFF THE WATER HEATER

Should it be necessary to turn off the water heater following commissioning, then

- Switch off or isolate the electrical supplies to the water heater AND the pump / controller
- Close the cold water valve at the water heater inlet



Note: If the water heater is located in a frost area and freeze protection valves are not fitted, damage to the panels may result if the water heater is switched off. Damage to the panels where no power is available at the pump / controller and where no freeze protection valves have been fitted is not covered by warranty



Astivita Limited
15 Suscatand Street
Rocklea QLD 4106
Ph: 1300 302 084

Email: service@astivita.com.au

Astivita Limited ABN 46 139 461 733

DRAINING THE SOLAR COLLECTORS

- Ensure power is switched off at both the water heater and controller
- Open a hot water tap and allow the hot water to run for a full 5 minutes immediately prior to draining the solar collectors. This will assist in draining high temperature water from the collectors back to the storage tank. After 5 minutes, the hot water tap may be closed.



NOTE: Extreme care must be exercised as water discharged from the solar collectors may be at a very high temperature

- Turn off the water heater (see above)
- Loosen fitting on top of solar panel return pipe
- Disconnect the solar cold pipe and water will drain from the solar collectors
- When water stops flowing from the solar hot and cold pipes, reconnect the solar cold pipe and retighten fitting on top of solar panel return pipe.

DRAINING THE WATER HEATER

- Ensure power is switched off at both the water heater and controller
- Open a hot water tap and allow the hot water to run for a full 5 minutes immediately prior to draining the solar water heater tank. This will assist in draining high temperature water from the collectors back to the storage tank. After 5 minutes, the hot water tap may be closed.



NOTE: Extreme care must be exercised as water discharged from the solar collectors may be at a very high temperature

- Turn off the water heater (see above)
- Operate the relief valve release lever carefully to release the pressure in the water heater – do not allow the lever to snap back or damage may result to the valve seat
- Undo the union at the cold water inlet and attach a hose to allow the water to drain from the tank
- Operate the relief valve again to allow air into the water heater which will allow the water in the water heater to drain away



Astivita Limited
15 Suscatand Street
Rocklea QLD 4106
Ph: 1300 302 084

Email: service@astivita.com.au

Astivita Limited ABN 46 139 461 733

PRODUCT WARRANTIES

ASTIsola is a brand owned by Astivita Limited (Astivita), a public company traded on the Australian Stock Exchange. Accordingly, this warranty is offered by Astivita and full contact details are shown at the end of this document.

In addition to the guarantees under the Australian Consumer Law (ACL), Astivita provides consumers (i.e. retail customers, not trade customers) a warranty that all products in its product range (products) will be free from defects in materials and workmanship under normal use for the period of time applicable to particular components of each product as set out in the table below.

The warranty periods listed in the table below relate to products purchased on or after the 1st January 2013 and commence from the date of original purchase. Note that in the case of a new home, the original purchaser may be the home builder in which case the warranty commences from the date of purchase by the builder.

If a product fails to conform to this warranty during the applicable warranty period, Astivita will either replace any failed component of the product or replace the product free of charge (which Astivita will determine in its absolute discretion).

Table of Applicable Warranty Periods

Hot Water Storage Cylinder & Solar Collector Panels	5 years
Electrical parts supplied by AstiVita, e.g. element, thermostat, pump & controller etc.	2 year
Associated valves supplied by Astivita including Frost Valves	2 year
Labour to replace or repair defect	2 year
Installation including copper pipes etc. as these are not supplied by AstiVita	Not applicable ²

Exclusions

1. This warranty and post warranty limited replacement offer only applies to defects which have arisen solely from faulty materials or Manufacturing in the product and does not apply to other defects which may have arisen as a result of, without limitation, the following:
 - Installation by a non-authorized person or installation that is not strictly in accordance with the manufacturer's installation instructions as described in the Installation and Owner's Manual;
 - Accidental damage, abuse, misuse, maltreatment, abnormal stress or strain of the products;



Astivita Limited
15 Suscatand Street
Rocklea QLD 4106
Ph: 1300 302 084

Email: service@astivita.com.au

Astivita Limited ABN 46 139 461 733

- Tarnishing and damage to or deterioration of finishes as a result of harsh or adverse conditions (including corrosive environments such as coastal locations, and inadequate ventilation and drainage of installation locations);
 - Fair wear and tear;
 - Excessive water pressure, blocked pipework, faulty plumbing, restricted flow or excessive temperature;
 - Scale formation or the effects of corrosive water where the product has been connected to a water supply that is outside the parameters outlined in the Installation and Owner's Manual;
2. Alterations or repair of the product other than approved by Astivita are not covered (for the avoidance of doubt, the attachment of accessories or use of non-genuine replacement parts other than those manufactured or approved by Astivita are not covered).
 3. Where the water heater is installed in a position that does not allow easy and safe access, the cost of accessing the water heater safely, including the cost of additional materials, handling and/or safety equipment, is not covered.
 4. Personal injury, property damage or economic loss, howsoever caused, will not be covered.
 5. The warranty is restricted to residential installations only. A separate warranty applies to commercial installations.
 6. Freight and travelling costs associated with the repair or replacement of the product in accordance with this warranty is not covered except where the product is installed inside a 25 kilometre radius of the business premises of the authorised ASTIsola service agent who carries out the repairs.
 7. Where a failed component or system is replaced under warranty, the balance of the original warranty period shall remain effective. The replaced part or system does not carry a new warranty.
 8. Solar collector glass damage or breakage is not covered under this warranty. Your household insurance policy should be extended to include damage or breakage of the solar collector glass.
 9. Freezing and frost damage is not covered under this warranty except where adequate precautions are taken in accordance with the instructions contained in this "Installation Instructions and Owner's Manual" and then only in accordance with the separate warranty coverage provided for any frost protection devices fitted.

Australian Consumer Law (ACL)

In addition to this warranty and post warranty limited replacement offer, certain legislation (including the ACL) may give you rights which cannot be excluded, restricted or modified. This warranty must be read subject to such



Astivita Limited
15 Suscatand Street
Rocklea QLD 4106
Ph: 1300 302 084

Email: service@astivita.com.au

Astivita Limited ABN 46 139 461 733

legislation and nothing in this warranty and post warranty limited replacement offer has the effect of excluding, restricting or modifying those rights.

If Astivita fails to meet a guarantee under the ACL, your remedy for such failure may be limited to any one or more of the following:

- replacement of the product;
- repair of the product;
- refunding the cost of the product;
- payment of reasonable costs of having the product repaired;
- payment in respect of the reduced value of the product.

As required by legislation, including the ACL, any claims for damage, or any consequential loss either directly or indirectly due to defects of any kind in a product will only be met by Astivita where the damage or loss was reasonably foreseeable by Astivita.

Our goods come with guarantees that cannot be excluded under the Australian Consumer Law. You are entitled to a replacement or refund for a major failure and for compensation for any other loss or damage. You are also entitled to have the goods repaired or replaced if the goods fail to be of acceptable quality and the failure does not amount to a major failure.

HOW TO MAKE A WARRANTY CLAIM

At the time of purchasing your water heater, you should ensure you receive an owner's manual and that details of your purchase, including the date of purchase and the serial number of the storage tank, are recorded therein. You should keep those documents in a safe place in case of a warranty claim as documentary proof of purchase or other tangible evidence will be required to make your claim. Claims can be made at the point of sale or by posting, or emailing a written claim to Astivita (contact details listed below) within 3 months of the appearance of a defect. Claims must include the following details:

- Date of purchase;
- Location of purchase;
- Proof of purchase; and
- Contact details including name, address, telephone numbers, and email address.

AstiVita's contact details are as follows:



Astivita Limited
 15 Suscatand Street
 Rocklea QLD 4106
 Ph: 1300 302 084
 Email: service@astivita.com.au

Astivita Limited ABN 46 139 461 733



ACN: 139 461 733
 15 Suscatand street, Rocklea QLD 4106
 Po Box 881 Archerfield QLD 4108
 Tel: 1300 302 084
 Email: service@astivita.com.au

WARRANTY FORM

ASTIsola

Manufactured and distributed by Astivita Limited

Please fill in the details hereunder and retain this warranty together with your purchase invoice, which must be presented when making a warranty claim.

OWNER'S NAME: _____

ADDRESS: _____

SERIAL NO: _____

INSTALLER'S NAME: _____

DATE OF INSTALLATION: _____

INSTALLER SIGNATURE: _____

This warranty does not exclude, limit or modify any warranty, condition or liability which is or may be implied or imposed on the Company by virtue of the Trade Practices Act, 1974, or any other statute, law, rule or regulation except for the extent to which the Company is lawfully entitled. Note that Astivita Limited is not liable for any expenses associated with making a warranty claim.

Please return to:

Astivita Limited
Po Box 881 Archerfield QLD 4108
E: service@astivita.com.au



Astivita Limited
15 Suscatand Street
Rocklea QLD 4106
Ph: 1300 302 084

Email: service@astivita.com.au

Astivita Limited ABN 46 139 461 733

MANDATORY INSTALL REPORT CHECKLIST

Attention: Installer - upon Commissioning; This Form must be completed and handed to the Builder or Householder.

The Installer is responsible for Commissioning & Testing - ✓ For “Yes”, x for “No”.

- Has the installation been installed in accordance with Workplace Health & Safety regulations?
- Is the Contractor Solar accredited?
- Has this system been installed to Australian standards AS3500.4 –1994 and Wiring Rules AS/NZS 3000?
- Has the contractor located the solar collectors where site drawing or order nominates? **(Collectors should be facing North for optimum efficiency).**
- Has the system been installed as per this “Installation Instructions and Owner’s Manual”?
- Has there been a 500kPa Pressure reducing valve installed?
- Have all supplied Valves, Fittings & Protection Boots been fitted.
- Have both Solar Collector sensor & Tank sensor leads been installed and TESTED to ensure they are functioning correctly?
- Have both the Flow & Return COPPER pipes been correctly insulated; Armor flex 13mm (or similar)?
- Does the pump light switch on when operating?
- Is either the Panel sensor Light or Tank sensor Light illuminated or flashing at any time?
- Are the Solar Flow & Return lines installed using Copper pipe? (Plastic Pipe or similar not acceptable)
- In areas where frost or freezing (below 5°C) is prevalent are FROST PROTECTION VALVES fitted?
- If installed where Frost is prevalent ensure that no form of booster isolation switch has been installed.
- Has the Air been purged from system?
- Has the circulation pump been tested to ensure water is circulating to and from the solar collectors?
- Have wires from the tank been connected in the meter box.
- Prior to leaving site have all joins & fittings been checked for leaks.



Astivita Limited
 15 Suscatand Street
 Rocklea QLD 4106
 Ph: 1300 302 084

Email: service@astivita.com.au

Astivita Limited ABN 46 139 461 733

I certify that ASTIsola solar hot water System is installed at the address shown below and has been installed to the manufacturer's requirements.

Installation Address: _____

City, State, Postcode: _____

Date of installation: _____

Serial Number of Tank: _____ **Plumber Name:** _____

License no: _____ **Plumber Signature:** _____

Brand Name	Model Name
ASTIsola	SP272P24OV
ASTIsola	SP342P24OV
ASTIsola	SP343P24OV